

Cobi 18 User Manual

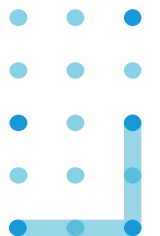

Overview Introduction



[symbol ISO 7000-0434
(2004-01)]

This User manual provides necessary operation and maintenance instructions about how to use the machine, it may be periodically enhanced or revised, please read this manual carefully and understand it well before operating or servicing it.



[symbol ISO 7000-0790
(2004-01)]

About Cobi 18

Cobi 18 is a commercial-purpose Cobot (Collaborative Robot) hard floor scrubber developed by ICE Cobotics. It is designed exclusively to scrub smooth hard floors in an indoor environment only, and it should only be used with the authorized accessories of ICE Cobotics.

About i-SYNERGY

Equipped with i-SYNERGY, Cobi 18 has a leading IOT system in the cleaning industry which is developed by ICE Cobotics. i-SYNERGY collects operating data from cleaning machines and transmits the information to the server. The server generates daily reports and sends them to designated users by email. From these reports, users will have information about each machines' usage, performance and even specific timings. In addition, i-SYNERGY also collects data on the lithium-ion battery, vacuum motor, brush deck motor, transaxle, and other electrical components, at least once every minute when the machine is in use and even during battery charging. i-SYNERGY will send notifications instantly to the server in case of any malfunction. ICE Cobotics maintenance personnel will receive a SMS within minutes from the server for immediate servicing.

About Cobi's Navigation System

Cobi 18 can be operated in either Autonomous Mode (without operator) or Manual Mode (with operator). When in autonomous mode, the machine is driven by the Navigation System. The Navigation System contains highly precise components such as the Navigation Control Unit, Lidar, Cameras, and Sensors, and as such, any components not being authorized for installation or use in the Navigation System might hinder or damage the functions of the Navigation System.

Cobi 18 should only be used by trained operators in controlled, restricted and approved environments. Approved environments shall also be limited to cleaning areas with adequate cellular communication signals permitting cellular data communicating with the machine to enable periodic safety-related updates.

The operator must be mindful when using Cobi 18 in accordance with its intended use and precautions at all times. Operators shall not, directly or indirectly:

- Operate Cobi 18 outside of the permitted use indicated by ICE Cobotics or in this User Manual;
- Modify, disassemble, tamper with, damage or misuse Cobi18, the Navigation System or software;
- Use outdoors or in an inappropriate environment not within the operational domain of Cobi 18 (including without limitation, exposure to excessive moisture, heat, humidity, water or use in location with steps, changes in gradient or low height physical hazards such as pools);
- Combine, operate or use of Cobi 18 with software, hardware, or other technology not provided by ICE Cobotics and approved for use in connection with Cobi 18;
- Fail to use or implement corrections, enhancements, modification, or upgrades provides by ICE Cobotics;
- Modify, improve, reverse engineer, duplicate, reproduce, or otherwise copy Cobi 18, the Navigation System, software or this User Manual (in whole or in part);
- Remove, modify, deface, or replace any of ICE Cobotics's or any third party's proprietary notices or marks which appear on, are affixed to, or are used in connection with Cobi 18.

Table of Contents

Safety Precautions.....4-7

Unpacking the Machine.....8-11

Machine Components.....12-13

User Interface Instructions..... 14

Machine Accessories..... 15

Machine Specifications..... 16

Machine Setup and Installation.....17-22

Machine Operation in Autonomous Mode.....23-32

Best Practices for Autonomous Mode.....33-34

Navigation System.....35-38

Manual Mode Operation.....39-40

Machine Maintenance.....41-46

Battery & Battery Charger.....47

Troubleshooting.....48

Fault Code & Solution.....49-50

Wiring Diagram.....51-52

Declaration of Conformity.....53

Safety Precautions

About Safety Precautions

Precautions presented here are intended to prevent harm to the user and other persons as well as damage to property. Always observe the precautions. ICE Cobotics shall not be liable for any damages incurred by the user or any third party who fails to follow any of these safety precautions and as a result of the malfunctioning, misoperation, trouble, etc. experienced by the machine, battery, or battery charger. This manual also gives safety precautions, correct handling procedures, and other regulatory information for using the machine, battery, and battery charger. Precautions given herein do not cover all possible situations that may arise. The safety of the operator and of passing and nearby persons is a priority in any situation (the machine is not operating normally, it has fallen over, etc.).



Always observe precautions regarding machine installation and use, and store this manual where it can always be referred to. In the following emergencies, immediately press the emergency stop button and turn off the main power switch.

- **The machine is in a hazardous state. (example: emitting smoke, is inoperable, has fallen over, etc.)**
- **The machine has come close to inflicting harm on surrounding persons or property.**
- **The machine is operating (behaving) unpredictably or is moving differently than given in this manual.**

Description of Symbols

The following symbol categories explain the level of harm or damage that may occur if indications are not observed and equipment is used incorrectly.

Read the guide after thoroughly understanding the indications.

 DANGER	Indicates a “probability of immediate danger of death or serious injury ^{*1} ” with incorrect handling.
 WARNING	Indicates a “possibility of death or serious injury ^{*1} ” with incorrect handling.
 CAUTION	Indicates a “possibility of slight injury ^{*2} and a probability of only physical damage ^{*3} ” with incorrect handling.

*1 Serious injury refers to loss of eyesight, injury, burns (high-temperature, low-temperature), electric shock, bone fracture, poisoning, etc. with lasting aftereffects and requiring hospitalization and long-term hospital visits for treatment.

*2 Slight injury refers to injury, burns, electric shock, etc. although hospitalization and long-term hospital visits for treatment are not required.

*3 Physical damage refers to damage extending to residence and property as well as livestock and pets.

Safety Precautions



DANGER

Do not operate machine:

- Unless trained and authorized.
- Unless you have read and understand the operator manual.
- Without first ensuring the cameras, sensors and other external components of the machine used for autonomous navigation are clean and undamaged before operating the machine.
- In flammable or explosive areas.



DANGER

- Do not use, recharge, or store the machine in a place subject to excessive moisture, temperature over 140°F / 60° C (near sparks or flames, near a heater, where there is direct sunlight, in a car on a hot day, etc.) or in a warm place or where heat collects. Maintain adequate ventilation and make sure not to cover with any kind of fabric.
 - * May cause deformation, malfunction, overheating, ignition, fire, electric shock, rupture, or damage or the battery to leak.
 - * It may also cause a portion of the case to become hot and result in burns.
- Do not drop, break, deform, puncture, gouge, burn, or paint the machine.
 - * May cause ignition, electric shock, damage, chemical explosion, etc.



DANGER

Servicing, disassembly, and repair is not possible by persons other than by ICE Cobotics or service staff approved by ICE Cobotics and having received appropriate training. May cause an accident such as fire, injury, electric shock, etc. or malfunction. May also cause leakage, overheating, rupture, ignition, etc. of the built-in battery pack.



DANGER

- Use only the supplied battery charger and battery when recharging the machine.
 - * May cause leakage, overheating, rupture, or ignition or overheating, ignition, malfunction, etc. of the battery charger.
- Do not touch the battery, or battery charger for a long time when recharging the battery.
 - * May cause low-temperature burns.



DANGER

- Do not allow the equipment to fall over or drop when moving or transporting it.
- Do not expose the machine to dust in large amounts, sand, snow, ice, water, humidity, saltwater environments, or brine mist (example: ocean environment, shore environment, etc.).
- Do not expose to warm air from a dryer, etc., bring into a sauna, or splash with hot water with a purpose such as drying equipment.
 - * May cause overheating, fire, electric shock, smoke, ignition, malfunction, injury, or leakage, overheating, rupture, ignition.



DANGER

- The machine is specifically for indoor use. Do not use outside such as on a street.
- Do not use the machine in a stepped location, on an uneven floor (braille blocks), or on a sloped surface over 2 degrees.
 - * The machine may fall over or drop and damage the machine or floor if travelling where there are steps.
 - * Travelling on an uneven floor may prevent the sensors from operating normally.
- Do not use the machine in locations with low height physical hazards such as pools.



DANGER

- If wearing an implanted cardiac pacemaker or implanted defibrillator, maintain a distance of at least 15 cm from the location of the implant.
 - * Electric signals may affect the operation of the pacemaker or defibrillator.
- Do not use it near electronic medical devices.
 - * The machine does not comply with UL or IEC 60601 standards (or equivalent standards).

Safety Precautions



WARNING

- Do not perform any operation not outlined in this manual.
- Do not place any decorative additions that may hinder the machine's operation or the emergency stop button.
- Do not cover the machine's sensors.
- Do not clean the machine with a high-pressure cleaner.
- Do not use the machine to collect hazardous or explosive waste.
- Do not block the machine's vents.
- Do not use where subject to vibration, impact, etc.
- Do not use the machine if the grounding strap is not in contact with the floor. If the grounding strap breaks or comes off, please contact ICE Cobotics customer service.



WARNING

- Use the equipment within an ambient temperature range of 35.6°F / 2°C to 104°F / 40°C, humidity of 10% to 80%. Also, store in a dry environment with no dust in an ambient temperature range of 35.6°F / 2°C to 104°F / 40°C.
- Do not allow liquid (tap water, refreshment beverage, seawater, pet urine, etc.) any electric conductive foreign objects (pencil lead, anything metal, metal necklaces or hairpins, etc.) to touch the charging terminals or external connection terminals or to enter the equipment. Otherwise, it may result in short-circuiting and cause fire, burns, malfunctioning, etc.



WARNING

- Be careful that dust does not adhere to the LIDAR sensor, camera, or other sensors.
- When using the machine in autonomous mode, follow the regular floor cleaning practice and use appropriate signage (cleaning in process signage).
- When using the autonomous cleaning mode, make sure that the operator is able to respond immediately to an alert received from i-SYNERGY. Not observing this may lead to an accident involving the user, third persons, surrounding objects, etc.
- Use the machine with its wheels always in contact with the floor. When using the machine in manual cleaning mode, avoid abrupt operation except where unavoidable.
- When the machine is not in use, store it in a safe location.



WARNING

- Only use power cord appropriate for the country where machine is being operated.
- Do not use the battery charger or power cable if damaged.
- Always unplug the battery charger from the outlet if not using it for a long time or when carrying out maintenance on it.



WARNING

- Use the battery only in the machine.
- Do not place objects on top of the battery.
- Do not subject the battery to impact, such as by placing objects on it or letting it fall.
- Do not throw the battery into a fire or heat.
- Do not connect the battery terminals with metal, etc.



WARNING

- Immediately discontinue use if anything unusual is noticed during use, recharging, or storage such as noise, smoke, odor, etc.
 - * May cause burns, fire, or electric shock.
- When lifting the machine from the floor, always use two persons as a safety precaution.
 - * Not doing so may cause injury.
 - * May cause the machine to malfunction.

Safety Precautions



CAUTION

- If there is an emergency, press the emergency stop button and then switch off the machine.
- If the machine is not operating normally (unusual sound, odor, smoke, etc.), immediately press the emergency stop button, to stop machine operation, turn off the main power switch, and contact customer service.
- Do not touch the machine while it is in operation other than in an emergency (except for during manual operation).



CAUTION

- Do not come close to the machine while it is in operation.
 - * When cleaning in autonomous cleaning mode, the machine sometimes suddenly turns, stops, or advances; coming close to the machine may cause injury.
- Do not allow feet or hands to come close to the bottom of the machine. Keep all infants, children and pets away from the machine.
 - * They may be pulled under the machine, causing injury.
- Do not insert any objects in the machine.
 - * May cause overheating, fire, malfunction, etc.
- Do not adhere stickers or tape to the sensors and wheels.
 - * May cause sensors to not operate normally or malfunction.



CAUTION

- The Battery is installed inside the machine, unless authorized, do not remove the Battery from the machine. Only use the ICE Cobotics specific battery.
- If you need to remove the battery from the machine, please turn off the ON/OFF switch of the battery first, then unplug the battery connector and gently pull out the battery.
- If the machine is not in use for a long time, recharge the battery regularly.



CAUTION

- Always keep the battery door open while charging to allow for proper ventilation.
- Always unplug the charger when not in use or when servicing the machine.
- If the battery charger is not operating normally, takes a longer time to recharge than normal, or if it produces sparks, smoke, odor, etc., immediately unplug it from the outlet, and contact customer support.
- If thunder is audible, unplug the battery charger from the outlet.
- Do not step on the power cable or subject it to excessive force when it is connected to the battery charger.
- Always hold the plug body and not the cord when plugging or unplugging the power cord.



CAUTION

- Always store the machine indoors, do not park the machine on a slope.
- Always store the machine in a dry area, do not store it in an area that may reach freezing temperatures.
- Always store the machine in its upright position, keeping the handle in its folded position.
- Always store the machine with the Brush Deck and Squeegee raised off the floor.
- Always store the machine with empty tanks. Please rinse the solution tank and clean the recovery tank before store the machine.
- Always leave the recovery tank lid open when storing the machine so the tank can properly dry out.

Unpacking the Machine

As a safety precaution, be sure to unpack with at least 2 persons.

- Inspect the packaging for any damage, do not discard the packaging and related materials. Securely store the packaging as it will be required when storing the machine for a long period of time.

1. Check the packaging for any damage, immediately report to the carrier if any damage is found.

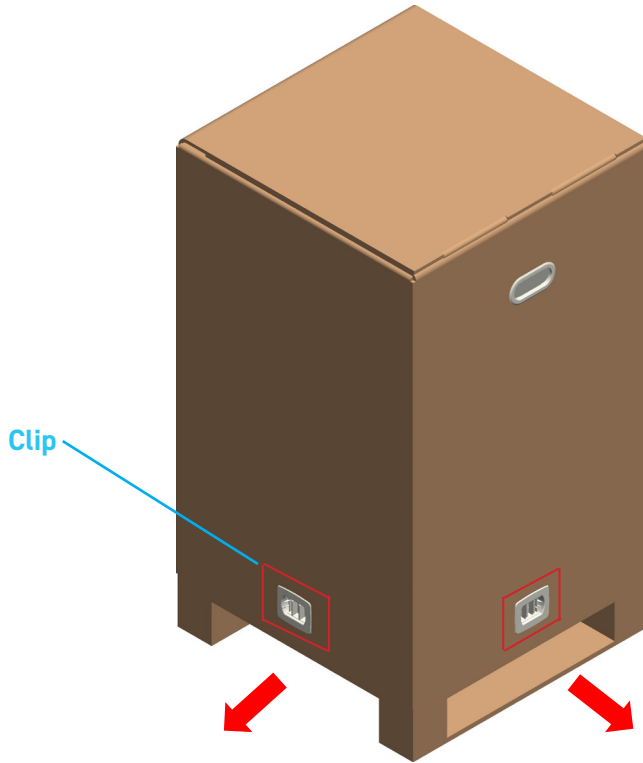

2. Remove the 4 clips that hold the upper box onto the base.

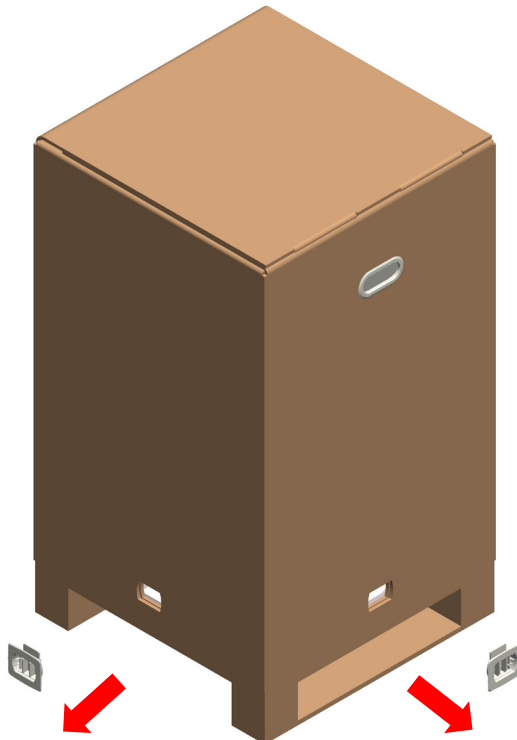

Unpacking the Machine

3. With 2 persons, hold the handholds on the outer box, pull it up and remove it completely.

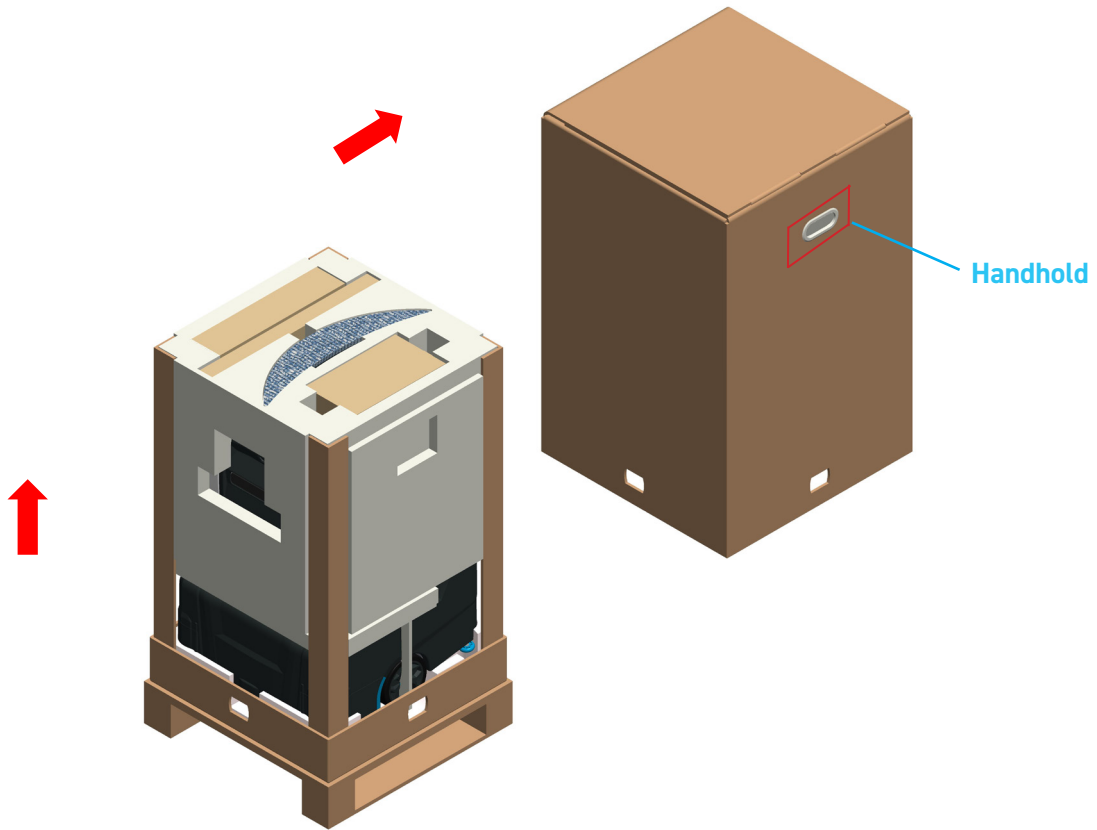

4. Remove the accessory boxes stored on the top of the packaging, it includes Main brush , Squeegee, Mop, Side brushes and Hopper.

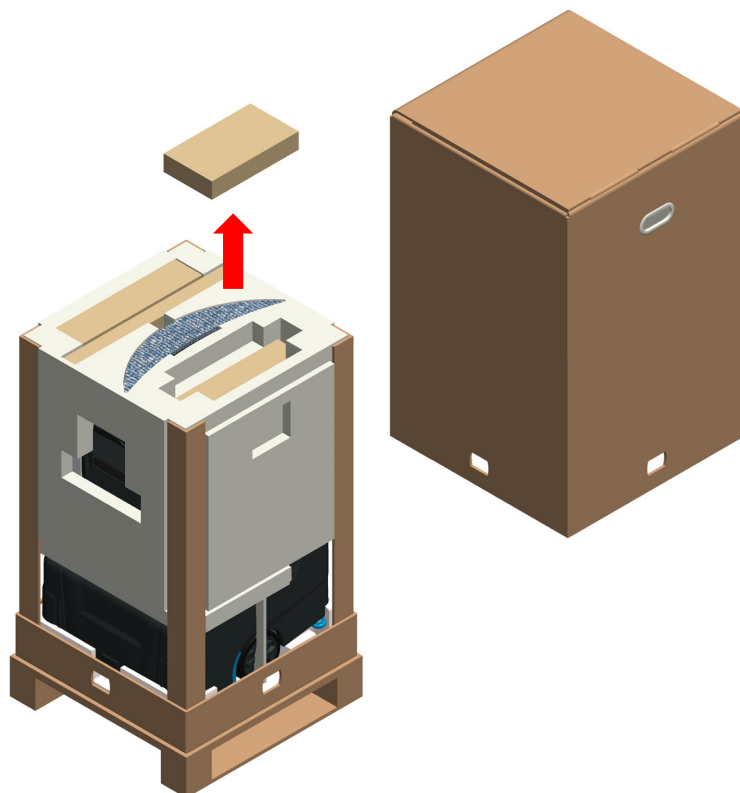

Unpacking the Machine

5. Continue to remove the packaging materials, including the upper foam and corner supports, fully exposing the machine.

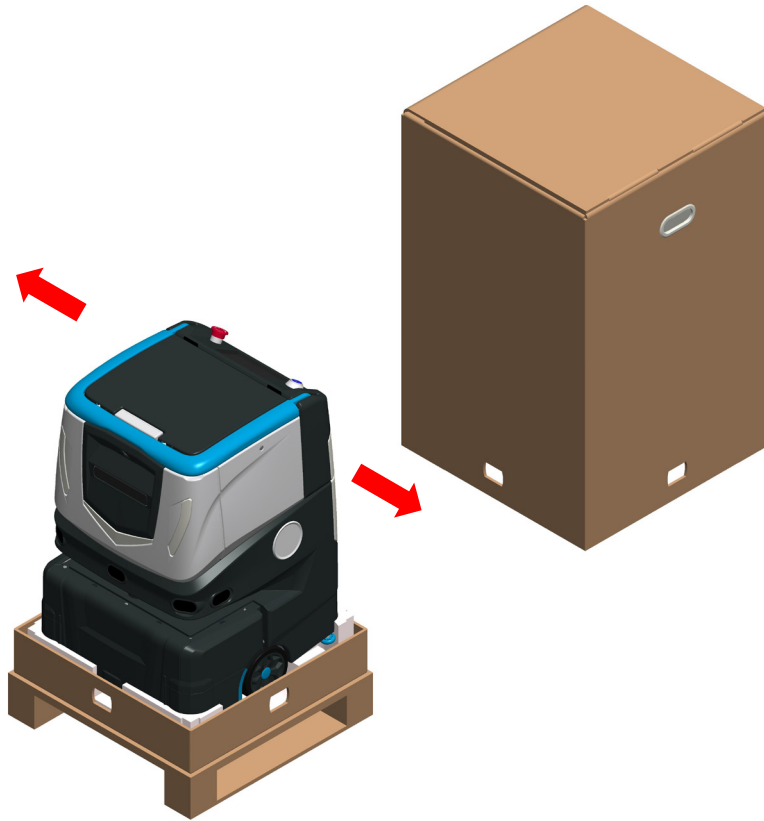

6. With 2 people, hold the hand holder on the machine, pull it up and remove it from the bottom box, then set it on the floor gently.

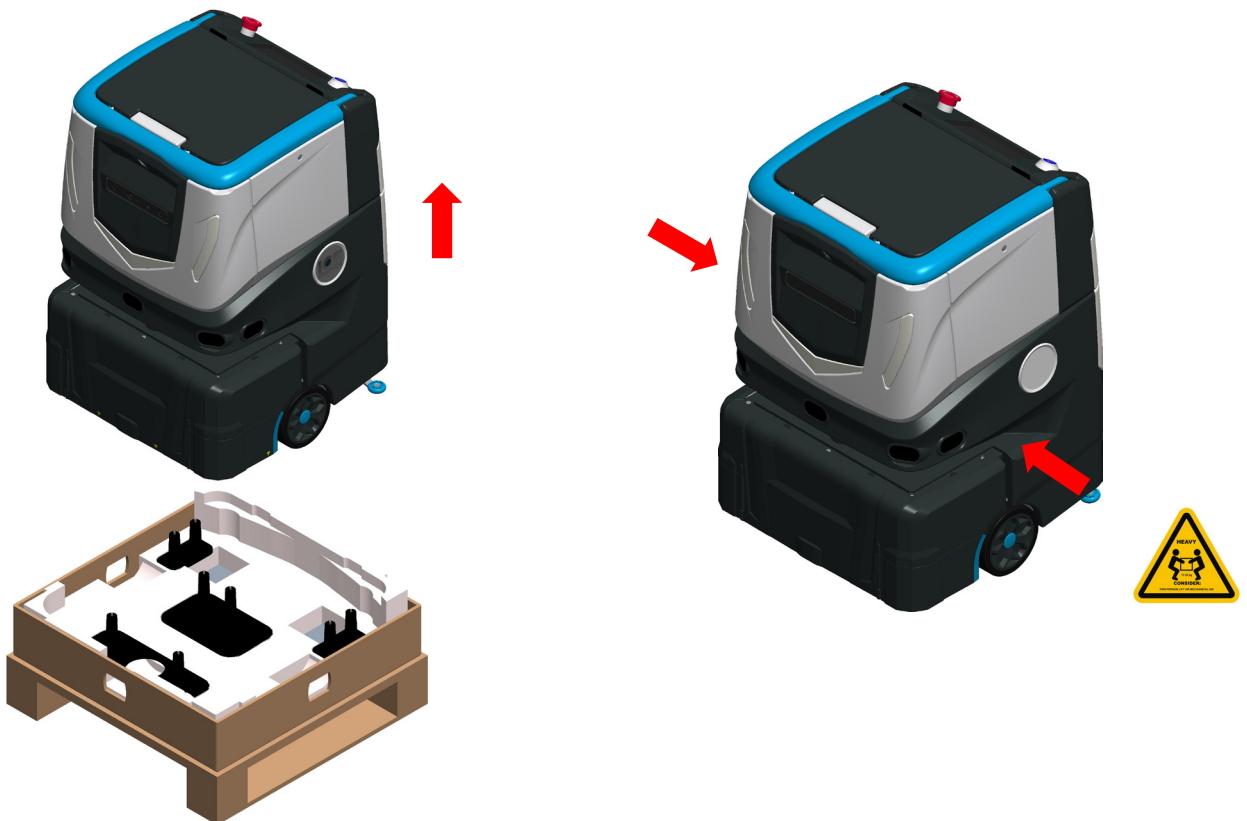

Unpacking the Machine

7. Remove the protective film from the Binocular Camera Module and 3DTOF.

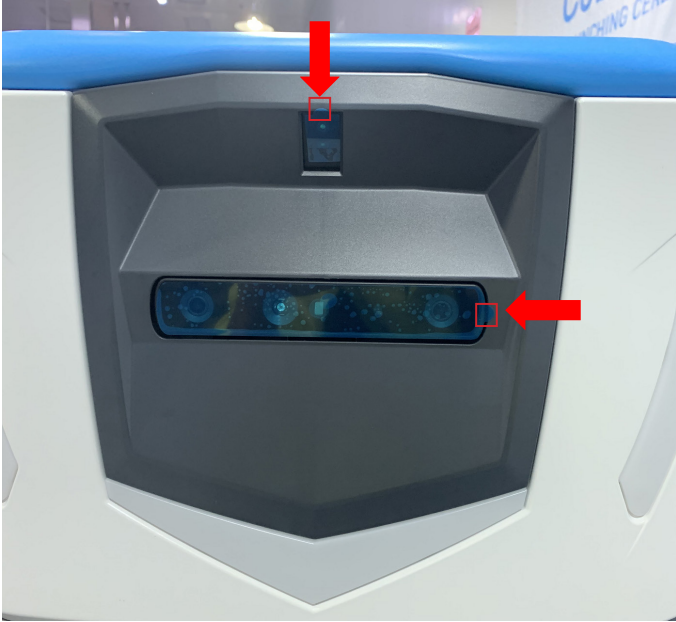

8. Gently lay the machine on its back on the floor with its front facing upwards, remove the protective film from the cliff sensors, unpacking is done.

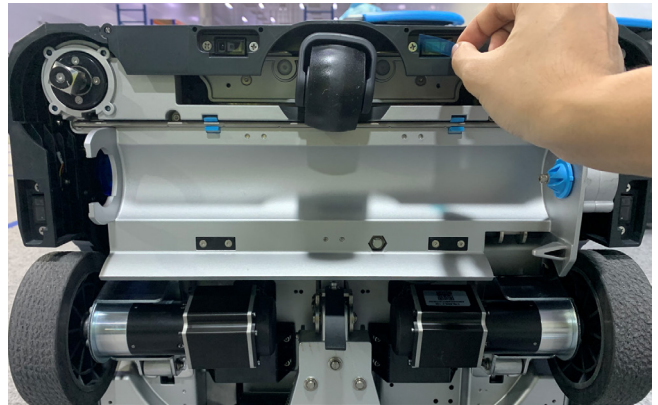
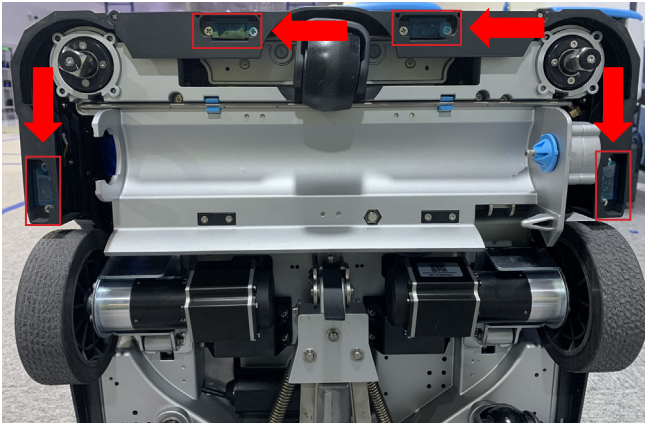

If the protective film is not removed, the machine may not work properly.

Machine Components

1. Transport Handle
2. 3DToF
3. Turn Signal, Left-Front
4. Binocular Camera Module
5. Turn Signal, Right-Front
6. Working Light, V-Shape
7. Ultra-Sonic Sensor
8. Lidar
9. Bumper
10. Side Door, Left
11. Side Brush, Left
12. Front Caster Wheel
13. Side Brush, Right
14. Side Door, Right
15. Traction Wheel
16. Machine Lifting Point
17. Tank
18. Turn Signal, Left-Rear
19. Go/Stop Button
20. Touch Screen
21. E-Stop Button
22. Main Power Switch
23. Rubber Stand
24. Turn Signal, Right-Rear
25. Door, Battery Compartment
26. Window, Battery Charging Status
27. Mop Lock/Unlock Button
28. Mop
29. Squeegee
30. Cap, Vacuum Motor Exhaust
31. Rear Caster Wheel
32. Hopper
33. Cliff Sensor
34. Main Brush

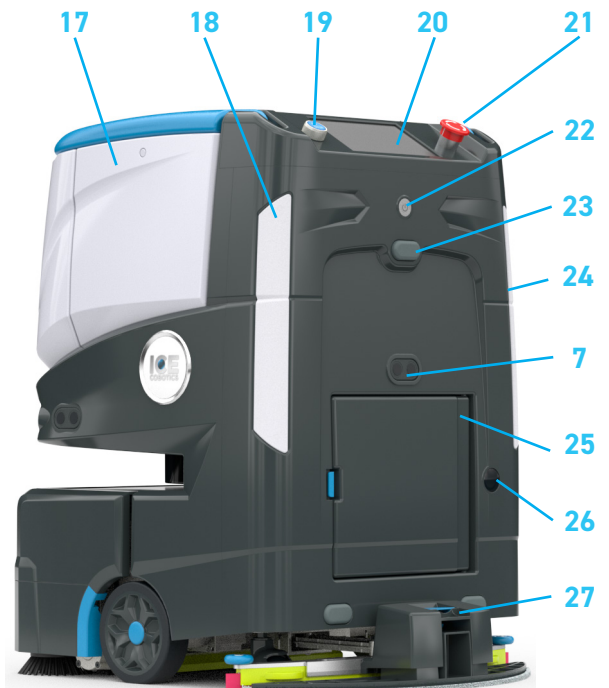
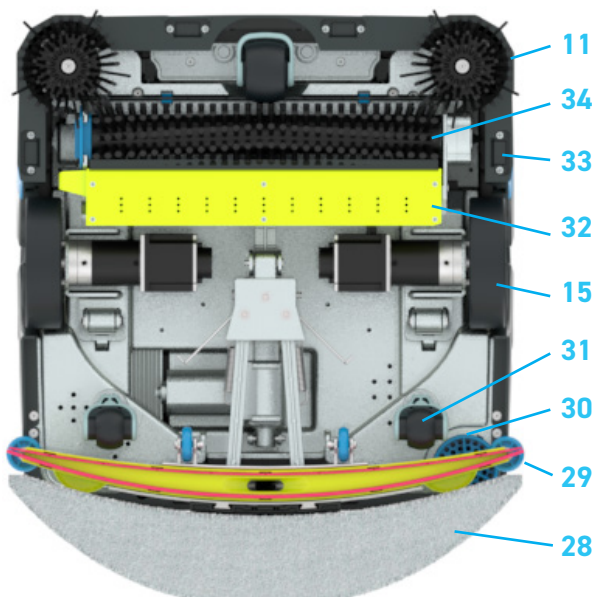
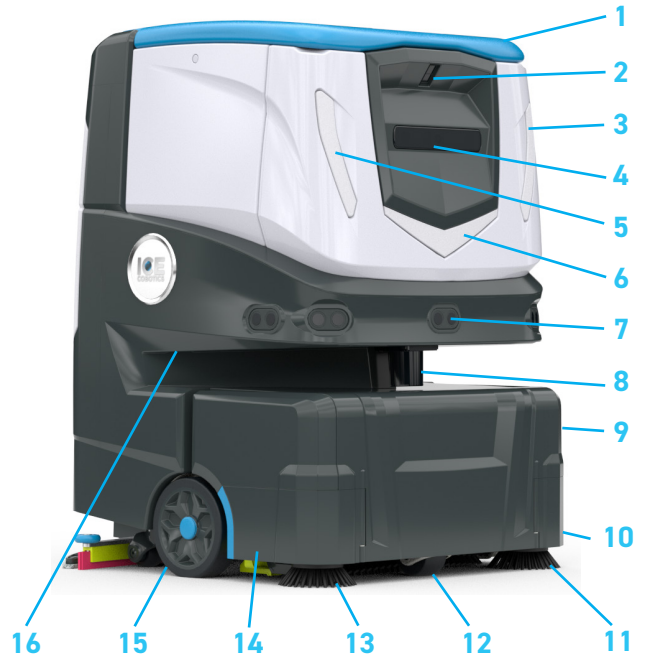

Machine Components

- 34. Power Cord, Battery Charger
- 35. Li-ion Battery
- 36. Fuses
- 37. ON/OFF Switch, Battery Power
- 38. Stopper, Battery Installation
- 39. Brake Push Button
- 40. Rubber Socket, Dirty Water
- 41. Rubber Socket, Filter
- 42. Filter
- 43. Rubber Socket, Vacuum Motor
- 44. Seal, Recovery Tank Cover
- 45. Solution Tank Cap
- 46. Float Housing, Vacuum Motor Shut-off
- 47. Vacuum Standpipe Assy
- 48. Dirty Water Standpipe Assy
- 49. Debris Collector
- 50. Recovery Tank
- 51. Handle, Tank
- 52. Solution/Recovery Tank Assy
- 53. Drain Plug, Clean Water
- 54. Drain Plug, Dirty Water

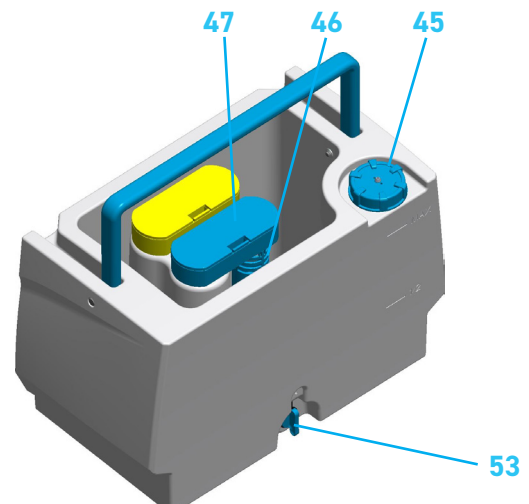
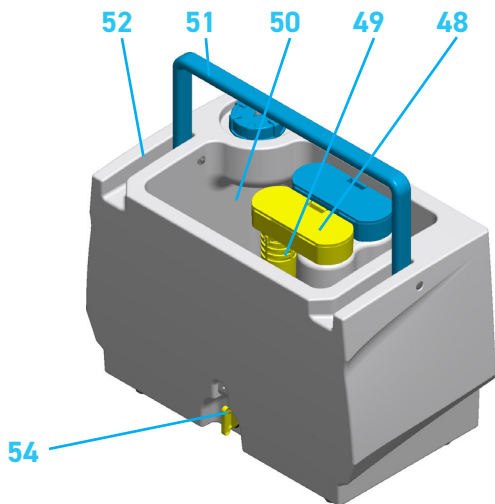
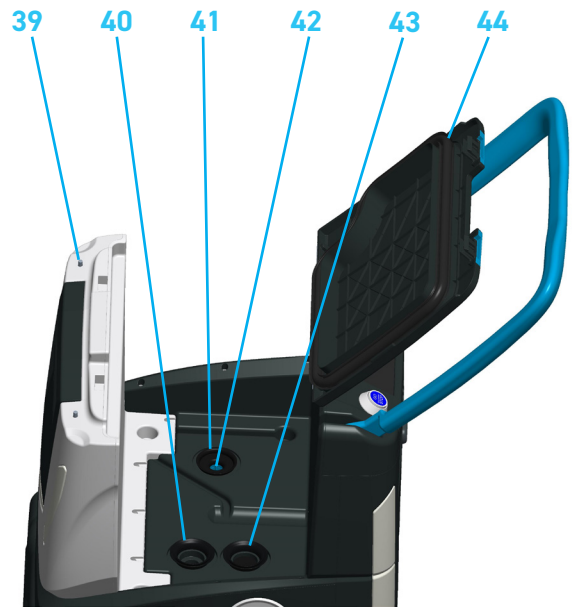
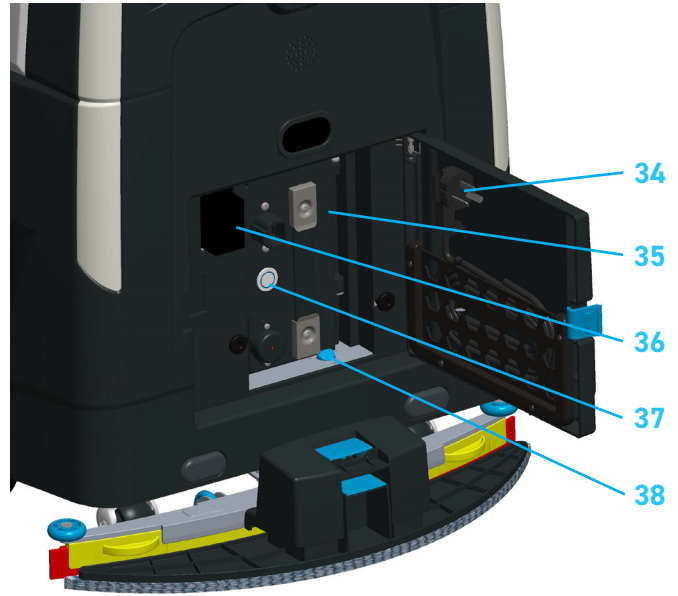

User Interface Instructions

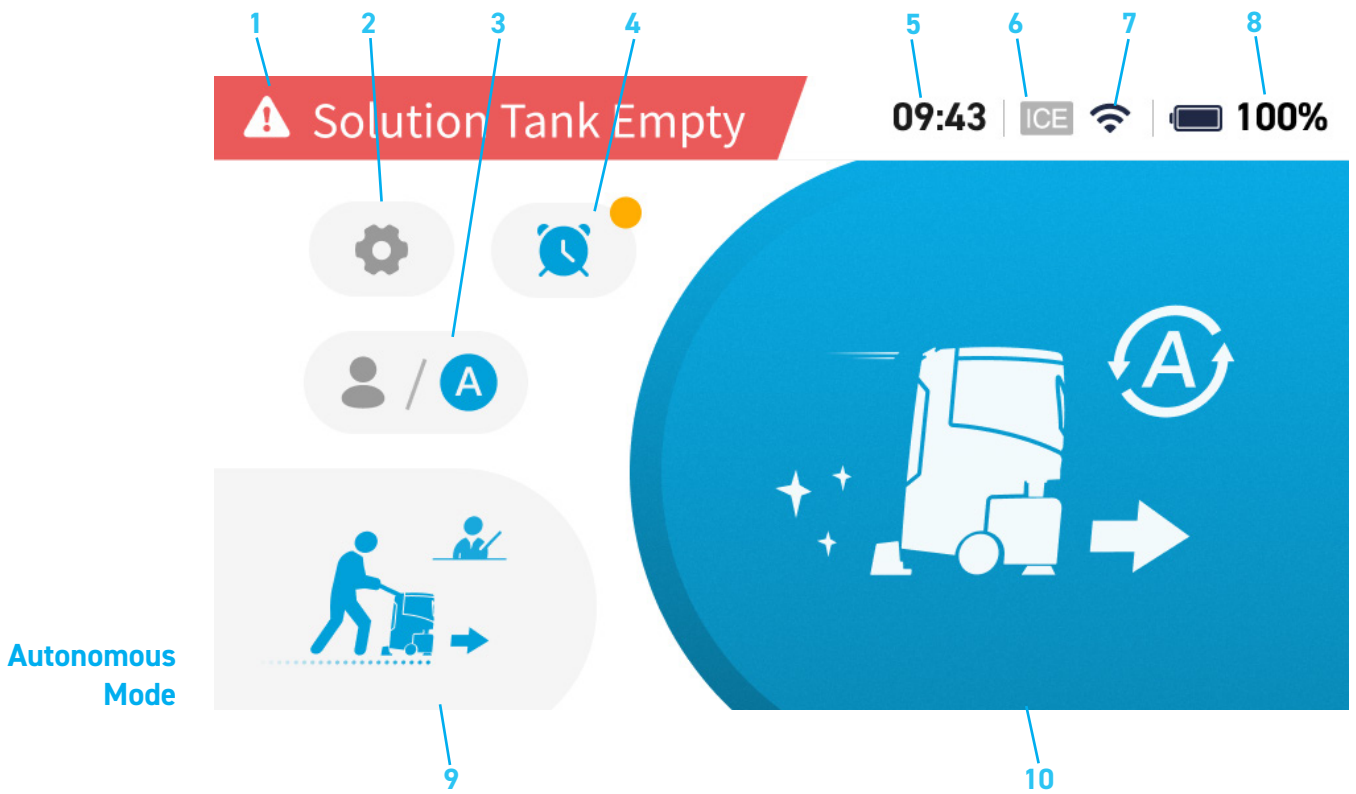

- 1. Warning Message Bar
- 2. Setting Icon
- 3. Manual/Autonomous Mode Icon
- 4. Timed Task Icon
- 5. Time
- 6. i-SYNERGY Cloud Connect Status
- 7. Communication Signal Status
- 8. Battery Condition Meter
- 9. Mapping Switch, Autonomous Mode
- 10. 1-Step Icon, Autonomous Mode
- 11. ECO/MAX Icon, Manual Mode
- 12. 1-Step Icon, Manual Mode

Machine Accessories

Included Accessories delivered with the machine.

Side Brush x 2

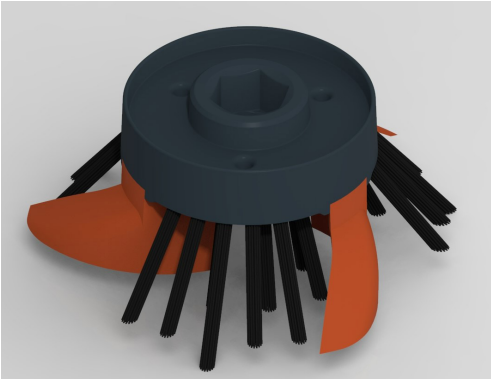

Main Brush x 1

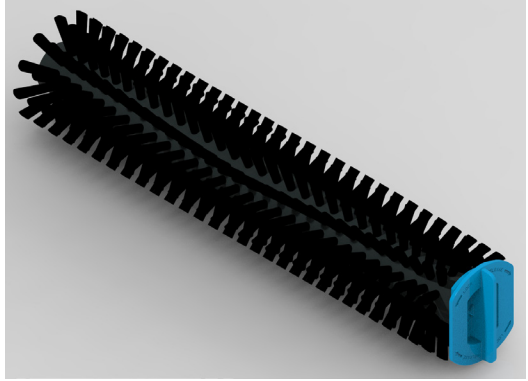

Hopper x 1

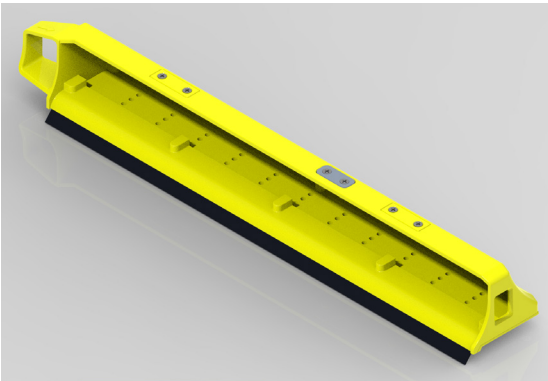

Squeegee x 1

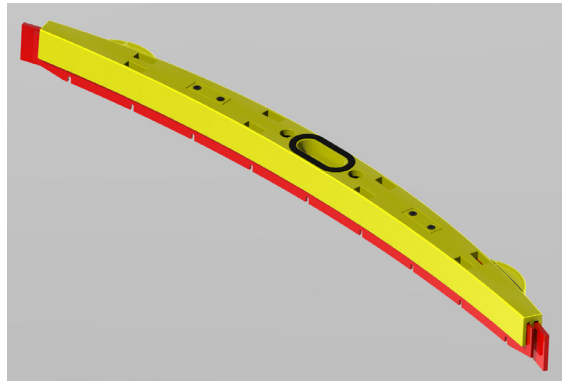

Mop x 1

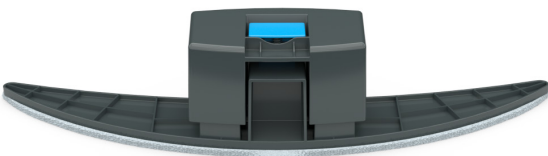

Home Location Code x 10

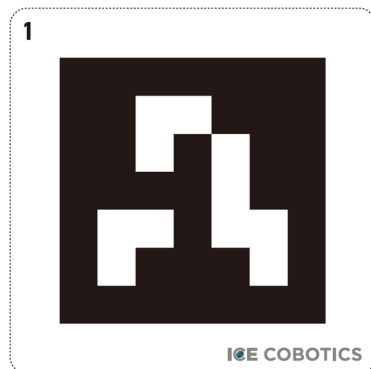

Machine Specifications

Model	Cobi 18
Product Name	18 inch Autonomous Hard Floor Scrubber
Dimensions (L x W x H)	480 mm x 500 mm x 700 mm 18.9 in x 19.7 in x 27.6 in
Voltage	24 VDC
Battery Capacity	25 Ah
Battery Charging Time	Approx 5 hr
Run Time	Approx 1.0-1.5 hr
Recovery Tank Capacity	11 L / 2.9 Gal
Solution Tank Capacity	10 L / 2.6 Gal
Hopper Capacity (In Theory)	0.4 L / 0.1 Gal
Cleaning Path Width	480 mm / 18.9 in
Productivity Rate (Projected)	500 m ² / 5380 ft ²
Drive Motor	2 x 60 W / 0.08 hp
Drive Wheel Size	∅127 mm / 6 in
Max. Travel Speed (Autonomous)	1.8 Km/h 1.1 mph
Side Brush Size	2 x ∅100 mm / 3.9 in
Main Brush Size	70 mm x 330 mm 2.8 in x 13 in
Side Brush Motor	2 x 12 W
Brush Motor	100 W / 0.13 hp 800 RPM
Vacuum Motor	300 W / 0.4 hp 560 mmH ₂ O / 22 inH ₂ O
Climbability (Autonomous Mode)	2%
Climbability (Manual Mode)	10%
Flow Rate	150 ml/min 5 oz/min
Min. Turn-Around Aisle Width (Autonomous)	650 mm / 25.6 in

Machine Setup and Installation

Main Brush Installation and Removal

1. Check and ensure the machine is turned off.
2. Remove the Tank assembly, Mop and Squeegee.
3. Gently lay the machine on its back on the floor with its front facing upwards.



DANGER

Do not lay the machine down unless the Tank, Squeegee and Mop are removed. Failure to remove components will cause water damage to the machine.

5. Open the right-side door, hold the installing hub of the main brush, ensure the socket on the end aligns to the drive gear correctly, turn left to lock the hub and install the main brush, turn right to unlock and remove it.
6. Close the right-side door, gently raise the machine and put it in the upright position.

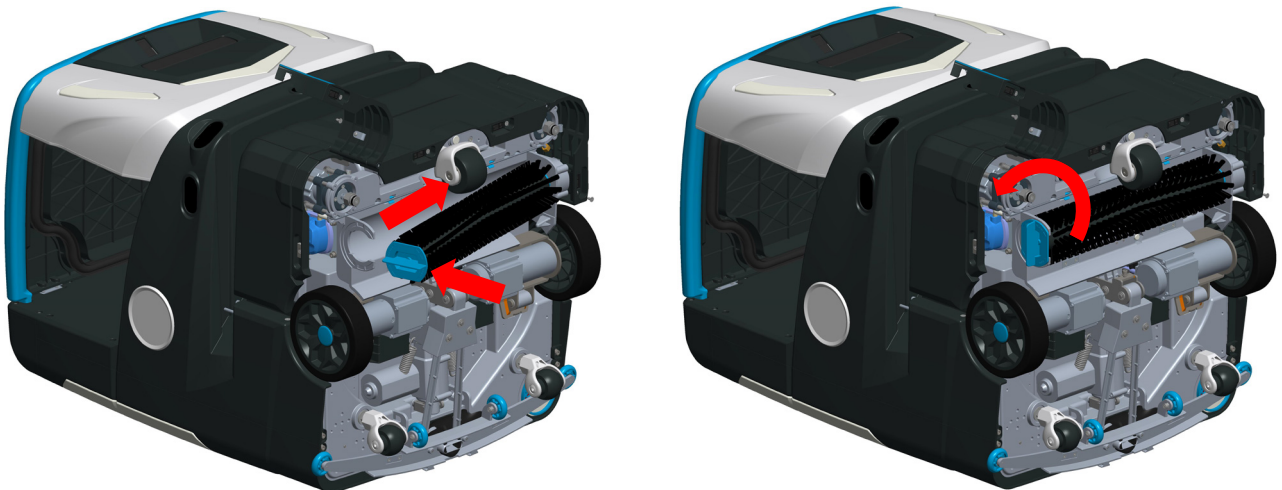

Machine Setup and Installation

Side Brushes Installation and Removal

1. Check and ensure the machine is turned off, and the brush deck is in the up position.
2. Open the Left side door, hold the side brush and ensure the install socket is properly aligned to the drive gear, simply push it up to lock and install, pull it down to unlock and remove, same procedure to install the Right-side brush.
3. Close the side door.



Machine Setup and Installation

Hopper Installation

1. Check and ensure the machine is turned off, and the brush deck is in the up position.
2. Open the Right-side door, hold the hopper on the end and ensure the magnetic surface faces up, simply push it in to lock and install, pull it out to unlock and remove.
3. Close the side door.



Squeegee Installation and Removal

1. Check and ensure the machine is turned off, the squeegee holder is on the up position.
2. Hold the squeegee by pinching the 2 ears, ensuring the magnetic surface faces upwards, simply lift it up to lock and install, pull it down to unlock and remove.



Machine Setup and Installation

Mop Installation and Removal

1. Check and ensure the machine is turned off, the squeegee holder is in the up position.
2. Ensure the squeegee is installed on the machine before installing the Mop Assy.
3. Attach the microfiber cloth Mop on the mop Holder via hook & loop before Installing the Mop Assy.

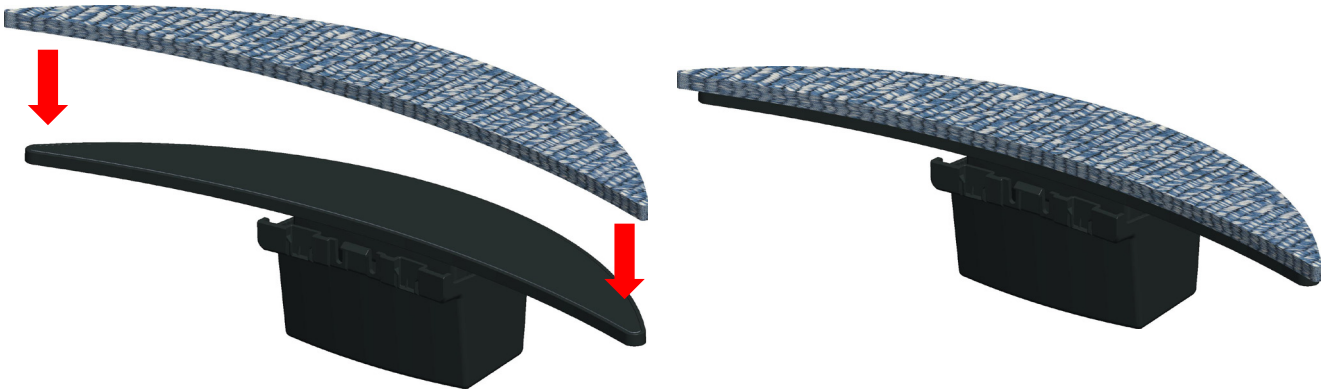

4. Hold the Mop Assy and align the socket on the Mop holder and the hook on the squeegee holder, push it down to lock and install the Mop, pull it up to unlock and remove.



Machine Setup and Installation

Filling the Solution Tank

1. Check and ensure the machine is turned off.
2. Raise the transport handle and the recovery tank lid, lift the recovery tank handle, then remove the tank assembly.
3. The Cobi 18 includes a combined tank, the inner cavity is the Recovery tank, the outer cavity is the Solution tank. Please drain the dirty water if there is still water inside the recovery tank before filling the solution tank.

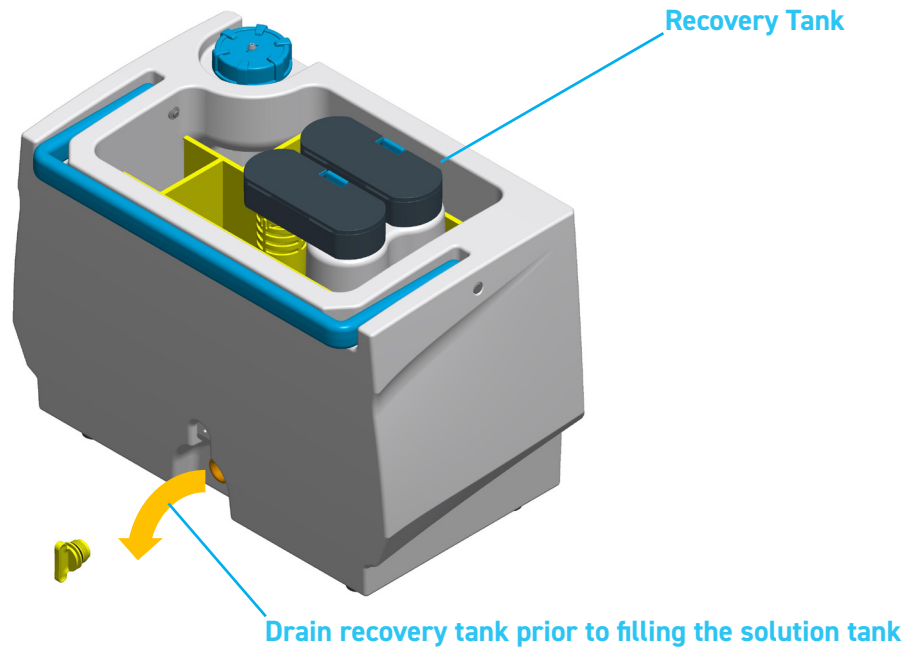

4. Remove the solution tank cap. Fill solution tank with clean water and the appropriate cleaning detergent.
5. Install tank back on the machine, ensuring the rubber stands align to the tank holder base.
6. Check around the machine and ensure there are not any water leaks.

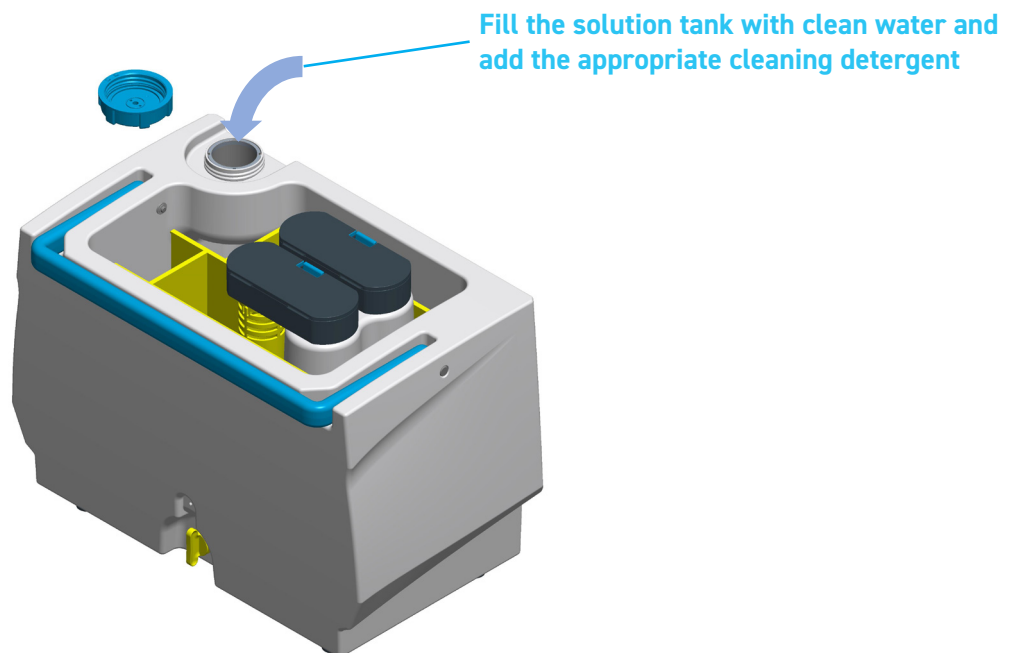

Machine Operation in Autonomous Mode

Overview

Cobi 18 is a Collaborative Robot scrubber and capable of cleaning in Autonomous mode and Manual mode. It is usually recommended to work in Autonomous mode.

To work in Autonomous Mode, the machine must first read a Home Location Code, then you can select to teach a cleaning route, or select a cleaning route saved on the Home location code to start work in Autonomous mode.

Here is the Operation flow chart.

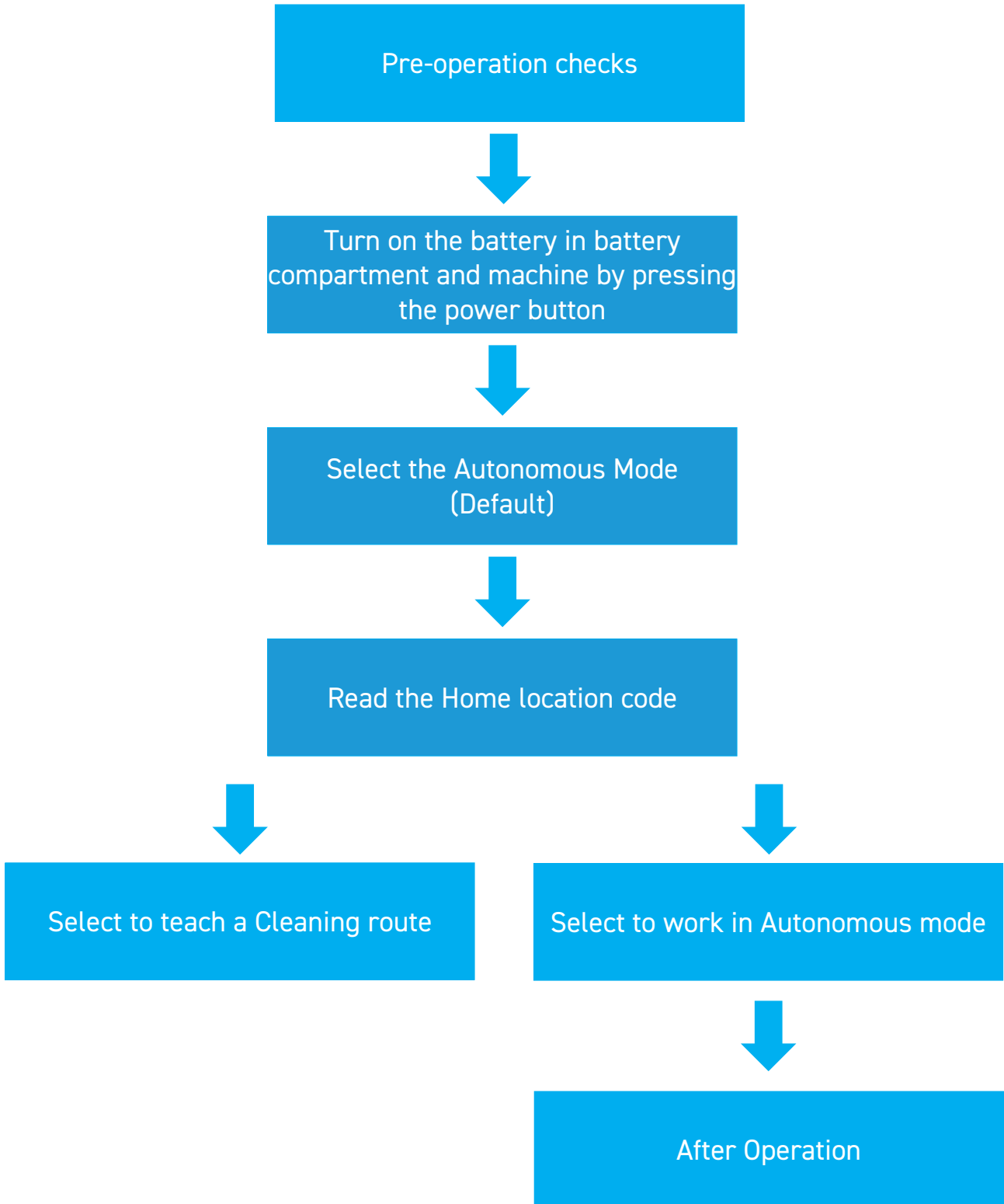

Machine Operation in Autonomous Mode

Pre-operation Checks

1. Ensure that all safety devices are in their correct positions. When the transport handle is folded, the parking brake will be on. When the transport handle is raised, the parking brake will be released.



WARNING

If the parking brake is not working correctly, the machine will not work in autonomous mode. Please contact ICE Cobotics customer service.

2. Check the cleanliness of all sensors, Lidar, camera, 3DToF, sensors and cliff sensors. Clean with microfiber cloth if necessary.



WARNING

If the sensors are dirty, the machine will not work in autonomous mode. Please clean with microfiber cloth if necessary.

3. Check the floor condition, please pre-sweep the area to be cleaned before scrubbing.



WARNING

Cobi 18 is a robotic scrubber, not a sweeper. The debris hopper is small. Please pre-sweep the area to be cleaned to remove large debris.

4. Check and ensure the battery is fully charged, charge the battery as needed.



DANGER

Fire or Explosion Hazard. Keep sparks and open flames away! Keep battery compartment open when charging. When battery is very low, do not continue to operate the machine. Battery damage may result.

5. Check the main brush for bristle wear. Replace and reinstall as needed.
6. Check the side brushes for bristle wear. Replace and reinstall as needed.
7. Check the debris hopper rubber blade for wear. Replace as needed.
8. Check the squeegee blades for wear. Replace as needed.
9. Check the mop for wear and replace as needed.
10. Check the filter for clogs and rinse as needed.
11. Drain and rinse the recovery tank completely. Fill solution tank with clean water and check for any leaks.
12. Check the recovery tank cover seal condition, check and ensure there are not any air leaks.



WARNING

Installing any component improperly may cause damage to the machine or impair cleaning performance.

Machine Operation in Autonomous Mode

Starting up the Machine

1. Unplug the battery charger power cord and store it on the back of the battery compartment door. Check and ensure the battery ON/OFF switch is turned on and gently close the door.

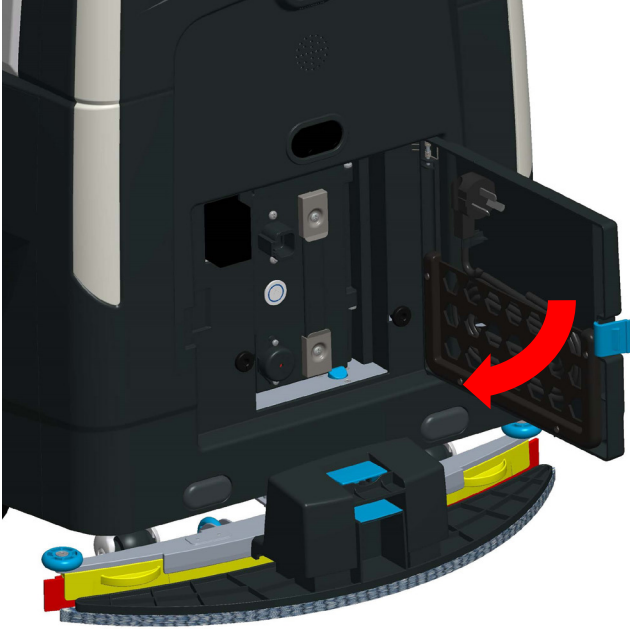

2. Press the main power switch and the touch screen will power up. After booting up, the main user interface will appear.



3. Check the screen for warning messages. If a message appears, touch the message and follow instructions on how to clear the warning. If warning fails to clear, please contact ICE Cobotics customer service.
4. Autonomous mode is the default cleaning mode.

Machine Operation in Autonomous Mode

Home Location Code Introduction

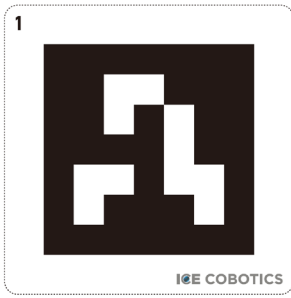

Home Location Codes are markers indicating where cleaning routes begin and end. They are used for establishing the machine's home location, and according to the size of the cleaning area, one or several Home Location Codes are used (6 cleaning routes can be saved for each home location code). In a building with several floors, a Home Location Code specific to each floor must be placed.

Placement of Home Location Codes

Place Home Location Codes on walls, columns, etc. in a well lit location and approximately 60 cm from the floor and approximately 80 cm from the machine.

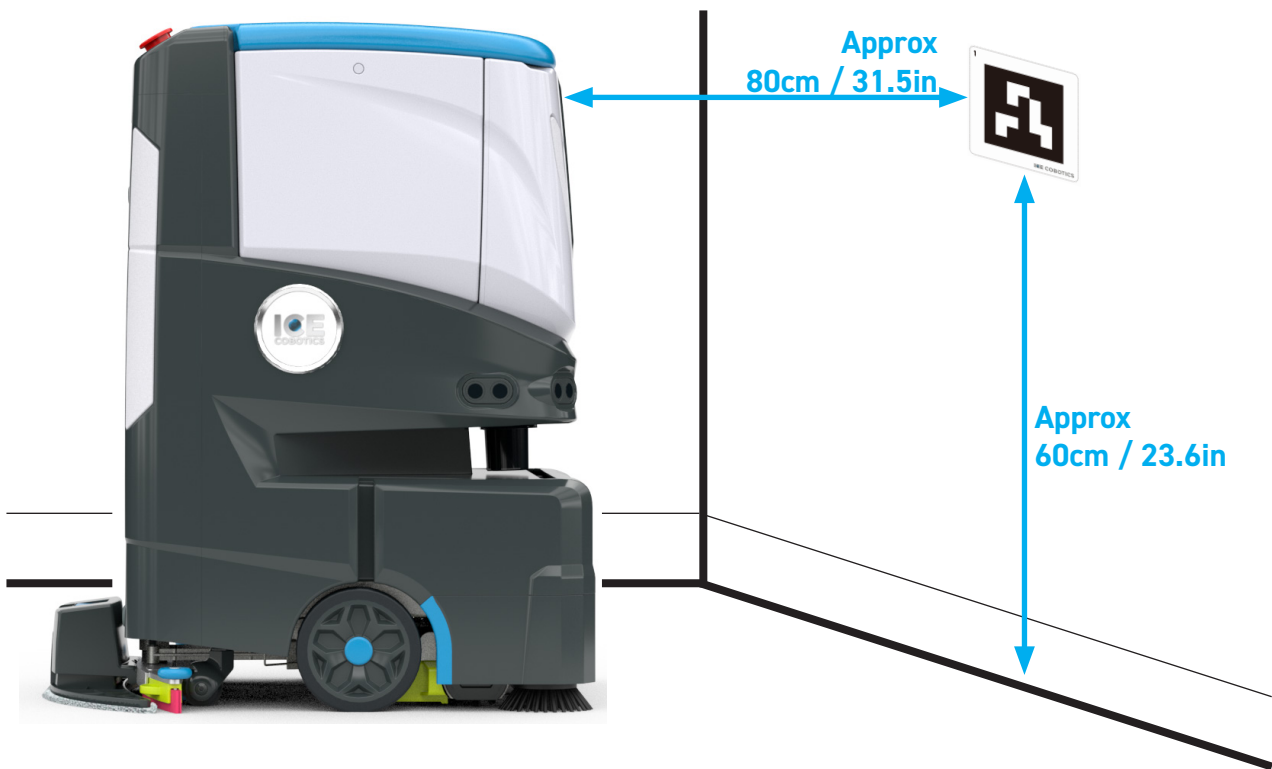

- Do not place Home Location Codes where they may be hidden, such as walls behind furniture or shelves.
- Mount the Home Location Code level to the ground and approximately 60cm / 23.6in off the ground, directly in front of the machine.
- Do not place Home Location Codes in a sleeve or cover, and do not copy on them or laminate them. The machine may not be able to read altered Home Location Codes.
- Avoid locations exposed to direct sunlight or strong light, and set them where lighting is consistent.
- Leave Home Location Codes permanently mounted. You must place them in the exact location each time. If codes are not in the exact location, autonomous cleaning will not occur.
- Each location code has an adhesive back, allowing them to be placed directly on walls, etc. Replace with new location codes if they have lost adhesion. Place location codes on a surface that will not peel when code is removed. Consult with building manager and place location codes in an approved location. Do not place on rough surfaces.

Machine Operation in Autonomous Mode

Teach a Cleaning Route

- 1. Select the Autonomous mode by touching the icon [A] on the screen.



- 2. Select the cleaning route teach mode by touching the corresponding icon on the screen, the UI will enter the Home Location Code scanning interface.

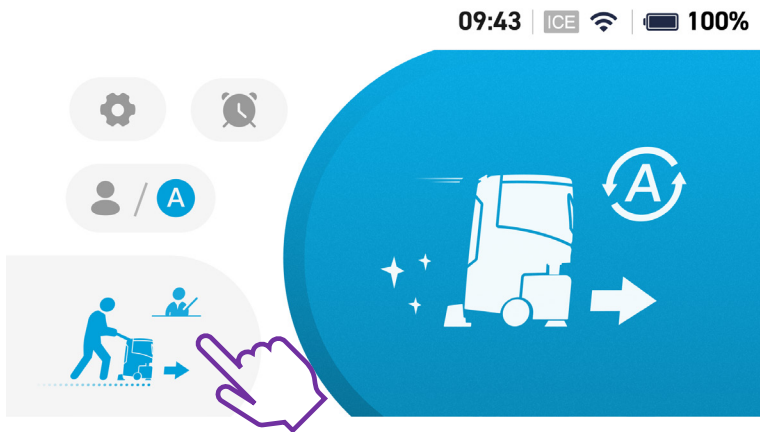

- 3. Push the machine to the front of the Home Location Code and scan it. The UI will then enter the cleaning route management interface.

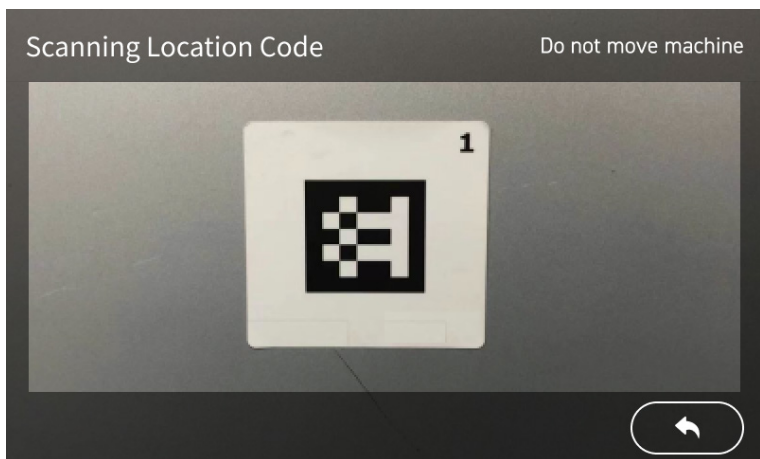

Machine Operation in Autonomous Mode

Teach a Cleaning Route

4. Touch the [+] icon to add a cleaning route. The UI will then enter the cleaning route mode selection interface.

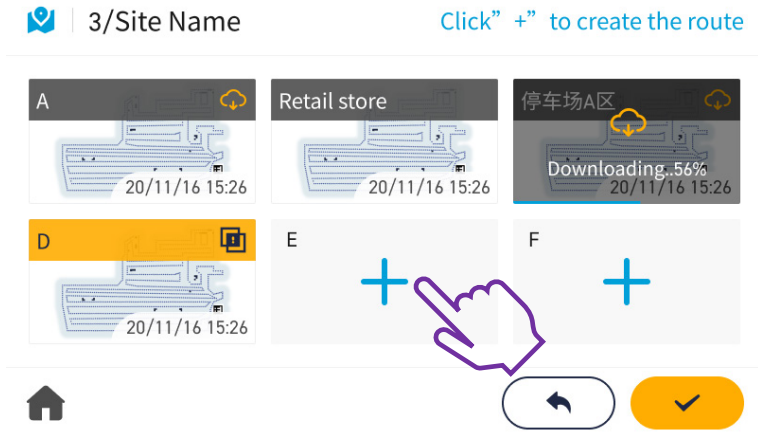

5. Cobi 18 has two different cleaning route modes. Custom mode and Auto-fill mode. Select the mode you want by touching the corresponding icon.

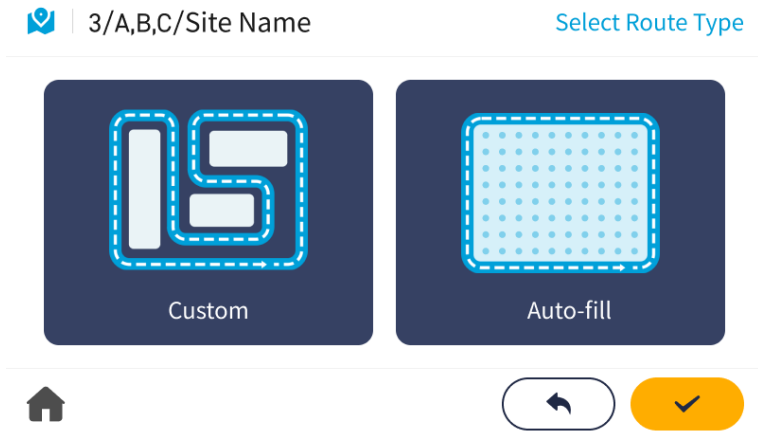

Custom route:

The machine will follow the exact cleaning route it was previously taught.

Auto-fill route:

Teach the outline of the area you want to clean, and the machine will automatically fill in the route when in Autonomous Mode.

6. Release the handle and push the GO/STOP button as shown on the animation on the control panel. The vacuum and brush motors will automatically turn on and the machine is now ready to be taught a route.

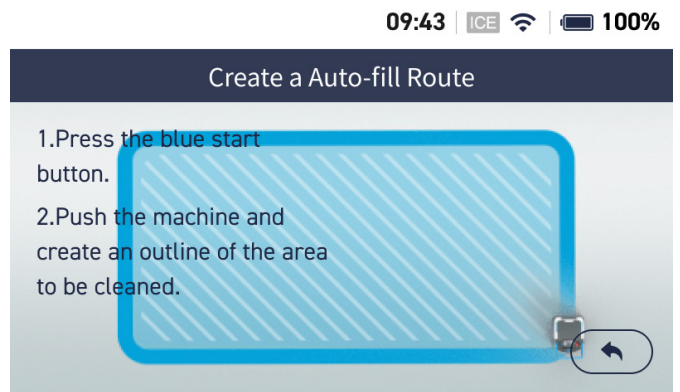
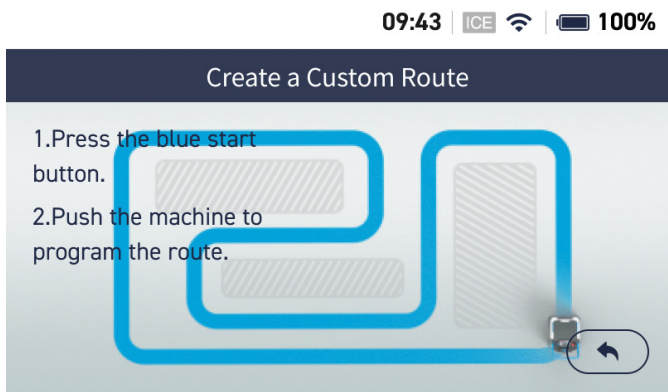

Machine Operation in Autonomous Mode

Teach a Cleaning Route

7. Push the machine along the route you wish to clean. The machine will learn the route you teach it. You may switch between ECO mode and MAX mode as needed.

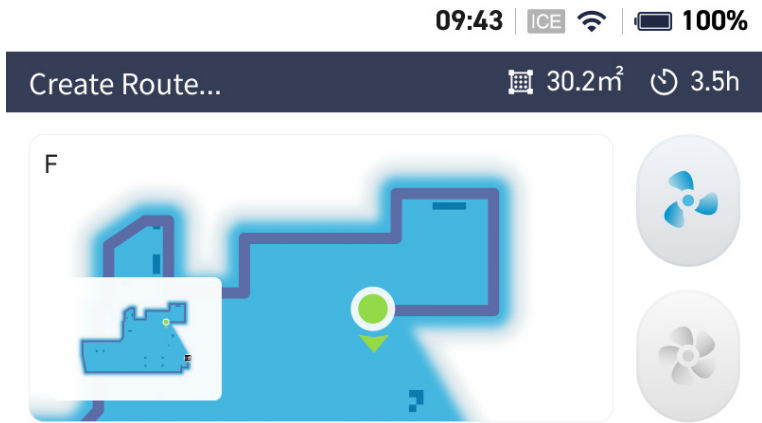

8. Once the route teaching is finished, push the machine back to the location code and direct the front camera to the location code. Touch the "save" icon and the machine will scan the location code and save the new cleaning route.

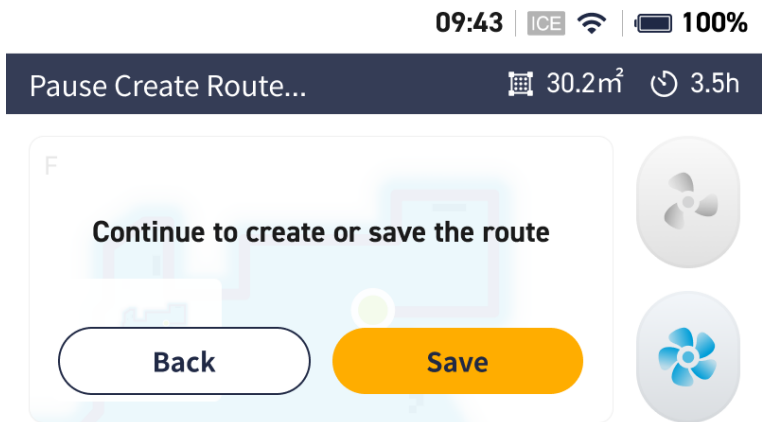

9. When the route has saved successfully, push the home icon and return to the Autonomous mode interface. The cleaning route is now completed.

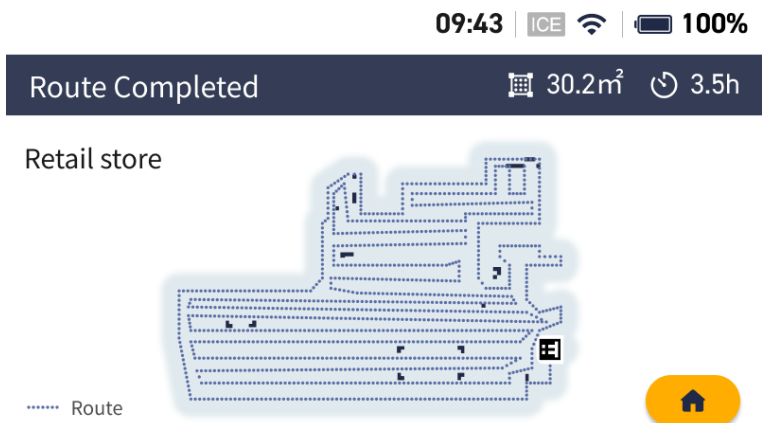

Machine Operation in Autonomous Mode

Work in the Autonomous Mode

- 1. Select the Autonomous mode by touching the icon [A] on the screen.

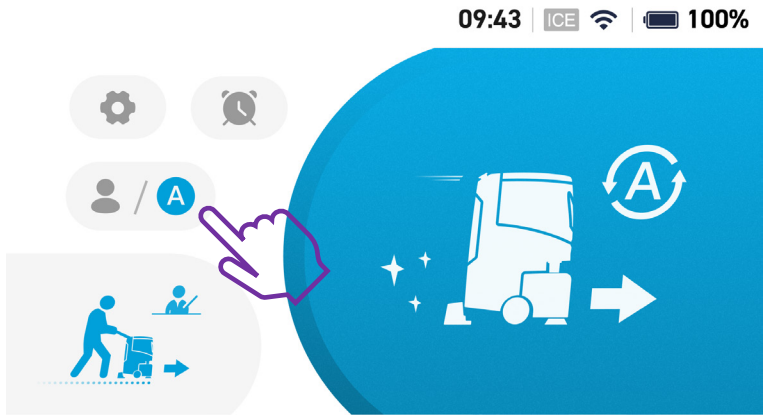

- 2. Select the Autonomous mode by touching the corresponding icon on the screen, the UI will enter the Home Location Code scanning interface.

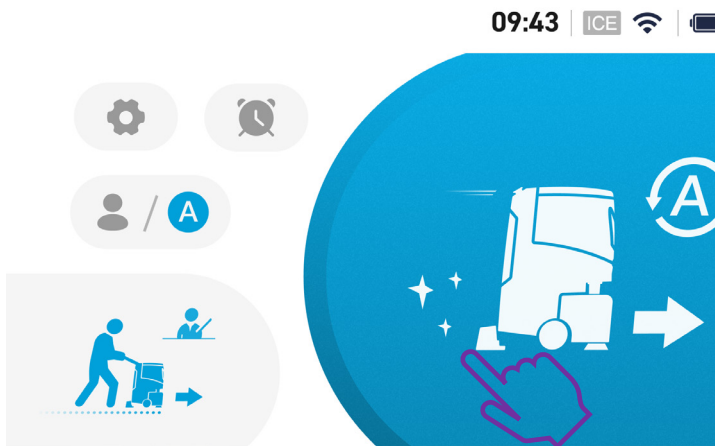

- 3. Push the machine to the home location code and scan it, entering the cleaning route selection interface.

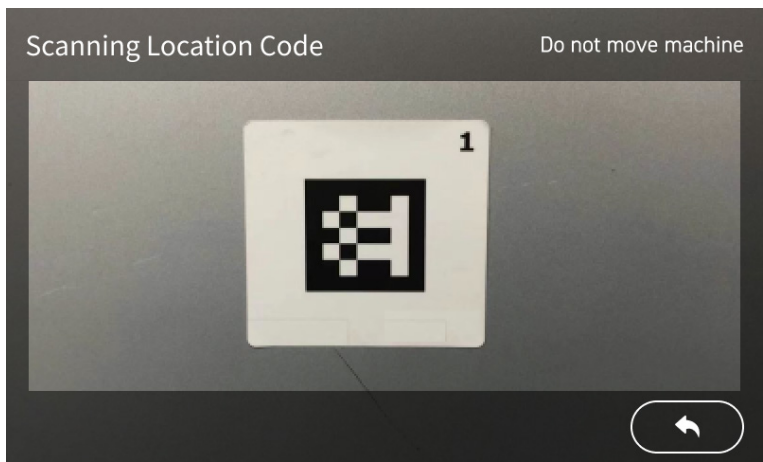

Machine Operation in Autonomous Mode

Working in Autonomous Mode

4. Push the corresponding icon to select the Cleaning Route(s) you want to clean, then touch on the icon [✓] to confirm your selection and enter the Cleaning mode selection interface.

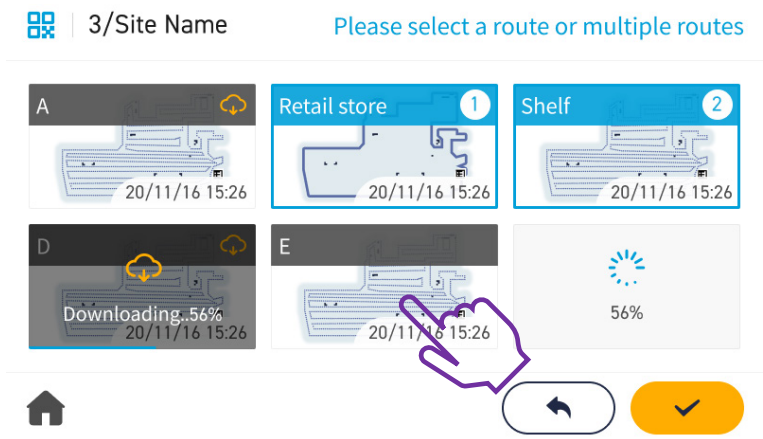

5. There are three possible cleaning modes when in Autonomous mode. Select the mode you want and push / tap the corresponding icon. Select the number of times you want to run the route and then push / tap the check mark to confirm your selection.

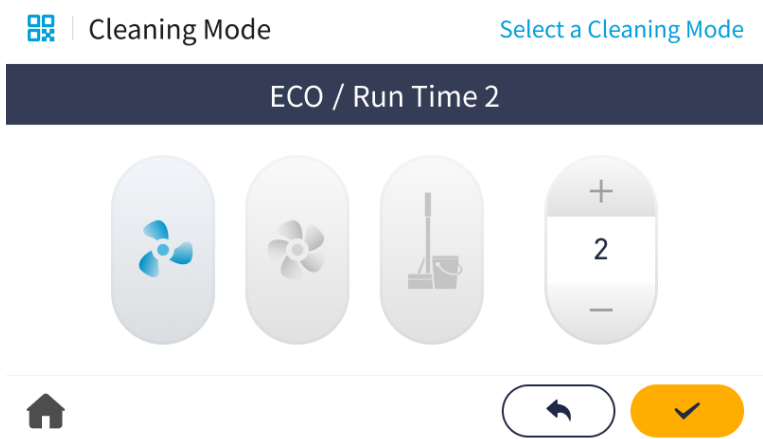

ECO Mode:
The machine will work in energy-saving mode. It is applicable for lighter duty scrubbing or when cleaning in a noise sensitive environment.

Max Mode:
The machine will work at full power, it is applicable for scrubbing heavily soiled floors.

Mop only Mode
Only the drive motors will be operational and the mop will pick up pre-existing moisture on the floor.

6. Lock the handle and push the GO/STOP button according to the animation on the screen. The vacuum and brush motors will turn on and the machine will begin to work in Autonomous mode.



Machine Operation in Autonomous Mode

Working in Autonomous Mode

- 7. While working in Autonomous mode, the machine will automatically clean the area on the selected route. The drive system will be controlled automatically and it will avoid obstacles while in autonomous mode.

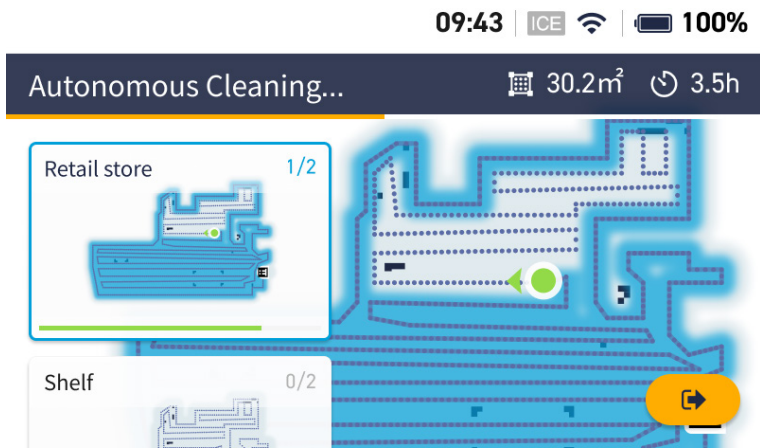

- 8. The machine will communicate with the cloud server of i-SYNERGY in real time while working. Cleaning progress can be checked on the i-SYNERGY app. If human intervention is needed, a message will be sent through the app. The operator may return to the machine and press the GO/STOP button to pause the cleaning process. Once the issue has been resolved, press the GO/STOP button to resume cleaning.

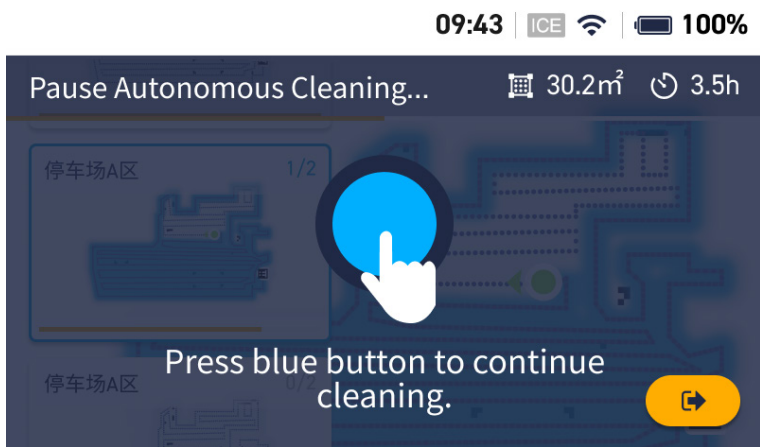

- 9. Upon completion of the route, the machine will automatically return to the starting point and scan the home location code, turn off all motors and apply parking brake. Autonomous cleaning is done.

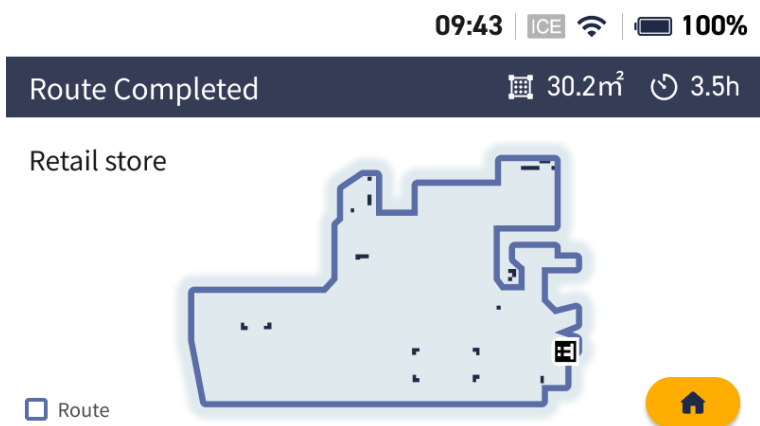

Teach & Map Routes

1. Refer to the zone maps that may already be in place to determine how large of a route to teach your cobot.
2. Teach routes when the area is most clear of obstacles and people that may block the scrubber's path. This may require teaching routes outside of your normal cleaning time. It is important to follow this instruction. If you teach your cobot prior to removing the obstructions the scrubber will not clean the specific area where the obstruction was previously located.
3. Determine if you are using "Custom route" or "Auto-fill route" mode based on the area you would like to map.
4. When teaching a route make smooth wide turns, avoid narrow aisles, and do not operate in reverse. Narrowly overlap routes for best coverage. Use the optional dry mop to limit residual water on turns. Following these parameters will help prevent the robot from getting stuck in tight spaces.
5. For teaching a route using the Custom route mode, teach the perimeter of your desired area only. The cobot will determine the best way to scrub the interior of the perimeter it just learned.
6. Avoid U-turns by alternating aisles whenever possible. Be mindful of edging too close to obstacles. If the area is open and has no obstructions, use Custom route mode for the most optimal teaching.
7. Avoid routes over 45 minutes in length - break up space into cleaning zones based on the capacity of water tank which could be impacted by water flow settings.
8. To move the scrubber through a non-scrubbable area, lift the scrub deck per operator guidelines.

Test Routes

1. Test all routes to ensure the unit runs each route successfully. Monitor the scrubber during testing and note any areas of difficulty. Your robot has a "safety bubble" around it making the footprint slightly larger, ensuring safe operation.
2. If you notice the unit calling for many "assists" when testing your route, scan the environment removing any obstructions. If the assists persist after obstructions are removed, please retrain the route.

Running Routes

1. Preparing the environment is key to successful robotic operation. It is essential to dust mop and remove temporary obstructions like inventory and other temporary obstructions. Be sure to push back any inventory that may be sticking out from its intended shelf area.
2. Run routes based on your pre-determined schedule. If that has not been decided, run routes when employees, customers and freight are not present. Also determine the best time of the day to perform this task.
3. Do not block the front of the scrubber where the cameras and sensors are mapping the room during use. Try and stay behind the unit during use.
4. During the start of any robotic route, check the scrubber's rear squeegee (and optional dry mop) to make sure they are adjusted properly. Pause the robot by pressing the blue button and adjust the squeegee or dry mop if necessary.
5. Optimize your run time, water flow and power usage, for daily floor maintenance, use lower water and power settings for longer water life and battery life.

Manual Mode

1. If you desire to run the scrubber in manual mode you can manually operate from the home location code by lifting the handle, turning the brushes and the vacuum on operating the unit.
2. You can also do this mid route by pressing the blue button, lifting the handle and operating manually.

Replacing Routes

1. If the environment changes significantly through remodel or permanent fixture move it may be necessary to teach a new route.
2. A new route will be needed when the dimensions of the space have changed so much that the scrubber is having trouble navigating and is calling for frequent assists. Some common examples of changes that can necessitate new routes include:
 - End caps in retail environments that narrow the aisle.
 - Displays in the main areas of the location, blocking its intended path.
 - New merchandise displays that might have different dimensions.
3. New dimensions may reveal new floor space that was previously covered causing the current route to miss this area. Please reteach this route for the new environment.

Navigation System

When Cobi 18 is in autonomous mode, the machine is driven by the navigation system. The Navigation system mainly contains the Computing Unit and Sensors which can be divided into Safety sensors and positioning sensors, the function is described as follow:

Description	Type	Function	Remark
Navigation Control Unit	Computing & Control Unit	The Core Computing & Control unit used for: <ul style="list-style-type: none"> Accepting the information from the sensors and Instructions from the User, generate and send instructions to control the movement of machine chassis. User Interface display and other interactive functions. 	
Lidar	Positioning Sensor	The 2D Laser Lidar is used for: <ul style="list-style-type: none"> Perceives the distance of the Obstacles on the emission plane. Give this information to location and position of Obstacles. 	Detection range: 50-1800mm Generally can avoid serious collision, but the positioning may produce deviation, cannot be stable detection of Glass, Mirror.
Binocular Inertial Navigation Module	Positioning Sensor	Contains the Stereo Camera and IMU function used for: <ul style="list-style-type: none"> Perceives the Acceleration and Angular velocity of the machine. Perceives obstacles in the front of and above the machine and measuring the distance. Identify pedestrians and elevators and do logic in advance. 	Detection range: 300-5000mm Cannot detect the Glass, Mirror.
3D ToF	Positioning Sensor	It is a 3D ToF which is AREA-ARRAY cameras used for: <ul style="list-style-type: none"> Perceives obstacles in front of and below the machine and measuring the distance. Identifies large gaps on the ground and plans avoidance routes. 	Detection range: 150-3000mm Cannot detect the Glass, Mirror.
Ultra-Sonic Sensor	Safety Sensor	Transceiver split-type Ultra-sonic sensor used for: <ul style="list-style-type: none"> Perceives obstacles and prevents collisions. 	Detection range: 100-3000mm The data only used for the movement safety detection.
Cliff sensor	Safety Sensor	Cliff sensor based on Triangulation method, used for: <ul style="list-style-type: none"> Perceives short range gaps in the floor, stopping machine. 	The machine should not be used when there is a risk of falling.
Bumper	Safety Sensor	Used for: <ul style="list-style-type: none"> Perceives a frontal contact with the machine, stopping it immediately. 	When the bumper is activated, the machine will stop immediately.

The Operating Environment and Restriction

1. The navigation system, including the Control Unit and all the sensors of Cobi 18 are designed exclusively to use in an indoor environment, DO NOT use the machine outdoors.
2. The cleaning area should not exceed 1500m². The maximum length shall not exceed 200 meters.
3. Cobi 18 is designed exclusively to scrub a smooth, hard floor. The maximum slope should not exceed 2 degrees.
4. For your safety, the minimum allowable aisle width is 800mm.
5. Cobi 18 should not be used in scenarios where the operating environment changes too much or too frequently, this will cause the machine to work with reduced navigation system accuracy, possibly causing it not to operate autonomously.
6. When Cobi 18 works in environments with insufficient monotonous information of environmental structure, it may produce large operation deviation, such as in a open area (no fixed object within 25m range) or long corridor without structural texture (the size of protrudes or depressions on corridor walls $\leq 100\text{mm}$ is regarded as corridor without structural texture, and the length should be $\leq 25\text{m}$).
7. Reflections, mirrors and some lighting may interfere with sensors causing a perception error. Please avoid such conditions.
8. Cobi 18 should be used in an environment as far as possible away from potentially dangerous areas, such as escalators, steps, infinity pools, etc. When using the machine in training mode to create a new cleaning route or cleaning area, do not pass through the potentially dangerous areas such as elevators, escalators, automatic doors, revolving doors and other facilities.
9. Cobi 18 sensors may receive interference from other devices such as robots, monitoring equipment, ultrasonic radar, etc. If interference occurs, please use these devices at different times.

Navigation System

Troubleshooting the Navigation System

Issue	Solution
<p>Machine operation is not smooth and machine stops suddenly.</p>	<ol style="list-style-type: none"> 1. Check and ensure all sensors are positioned correctly. 2. Check and ensure work surface does not exceed a 2 degree slope. 3. Check and ensure machine posture does not have great changes. 4. Check and ensure there is no debris on the lidar. Clean lidar with microfiber cloth. 5. Check and ensure there is no debris on the 3D ToF, Clean it with microfiber cloth. 6. Check to see if there are any objects interfering with the lidar. Remove obstructions. 7. Please contact ICE Cobotics customer service if issue continues to exist.
<p>Machine hits obstacles placed in a high position.</p>	<ol style="list-style-type: none"> 1. Check and ensure there is no debris on 3D ToF, clean it with microfiber cloth. 2. Check and ensure there is no debris on Binocular camera module, clean with microfiber cloth. 3. Please contact ICE Cobotics customer service if issue continues to exist.
<p>Large deviation in route while running in autonomous mode.</p>	<ol style="list-style-type: none"> 1. Ensure there are no new obstructions such as reflections, mirrors, glass in the environment. Remove prior to using machine. 2. Check whether the working environment is monotonous and spacious, the machine should be not used in this scenario. 3. Please contact ICE Cobotics customer service if issue continues to exist.
<p>Home Location codes can not be recognized.</p>	<ol style="list-style-type: none"> 1. Ensure there is not any dirt, residue or damage on the Home Location Code. Replace with a new one if necessary. 2. Ensure the Home Location Code is in consistent lighting. If located in an area with shadows or streaks, relocate code to new area with consistent lighting. 3. Ensure there is no debris on the Binocular camera module. Clean with microfiber cloth. 4. Please contact ICE Cobotics customer service if issue continues to exist.
<p>Machine not working properly.</p>	<ol style="list-style-type: none"> 1. Ensure there are no obstructions on the wheels such as string or hair wrapped around the axle. Remove obstructions as needed. 2. Please contact ICE Cobotics customer service if issue continues to exist.

Navigation System

Troubleshooting the Navigation System

Issue	Solution
Machine stops route early and returns to Home Location Code.	<ol style="list-style-type: none"> 1. Ensure working environment is not too narrow and there are not any new obstacles. Remove new obstacles as needed. 2. Teach new route if necessary. 3. Please contact ICE Cobotics customer service if issue continues to exist.
Machine bypasses some of the cleaning route.	<ol style="list-style-type: none"> 1. Check and ensure sensors are positioned correctly. 2. Check and ensure the environment does not exceed a 2 degree slope. 3. Check and ensure machine posture does not have significant changes. 4. Check whether the traction wheels wear is consistent. 5. Please contact ICE Cobotics customer service if issue continues to exist.
Machine not moving in straight line.	<ol style="list-style-type: none"> 1. Check and ensure lidar is not damaged and is in the correct position. 2. Check and ensure the traction wheels move freely and are in good working condition. 3. Please contact ICE Cobotics customer service if issue continues to exist.
Main display screen shut down.	<ol style="list-style-type: none"> 1. Check and ensure battery is charged. Recharge if necessary. 2. Check for any loose cables. 3. Please contact ICE Cobotics customer service if issue continues to exist.
Route creation failed.	<ol style="list-style-type: none"> 1. Please try to retrain new route. 2. Home location code may have moved while creating route. 3. Ensure there are no new obstructions such as glass or mirrors in the cleaning path. Remove as needed. 4. Please contact ICE Cobotics customer service if issue continues to exist.
Self-check failure.	Reboot machine and contact ICE Cobotics customer service if issue continues to exist.

Manual Mode Operation

Overview

Cobi 18 Manual Mode is typically used for cleaning smaller areas which can not be cleaned autonomously. When in manual mode, the machine operates as a traditional scrubber and the operator will not need to utilize the Home Location Code.

Pre-operation Checks

Manual mode pre-operation checks are the same as the Autonomous mode checks. Please refer to page 23 for details.

Starting machine

Starting the machine in Manual mode is the same as in Autonomous mode. Please refer to page 24 for details.

Manual Mode Operation

- 1. Tap the Manual Mode icon on the main user interface as shown below.



- 2. Tap the 1-step start icon as shown below.

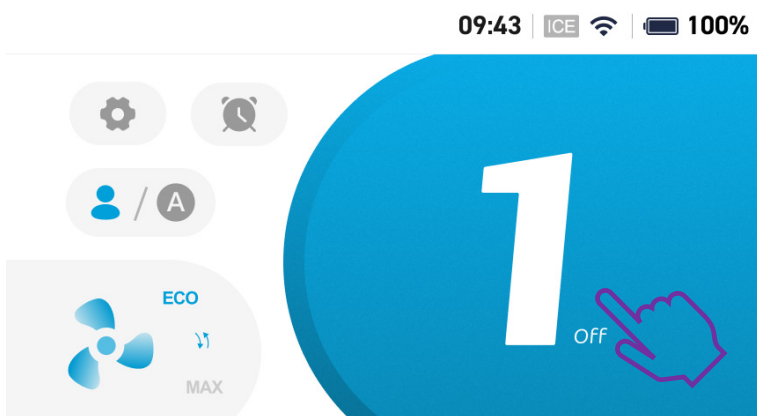

Manual Mode Operation

Manual Mode Operation

3. Tap either ECO Mode or MAX Mode as shown below.

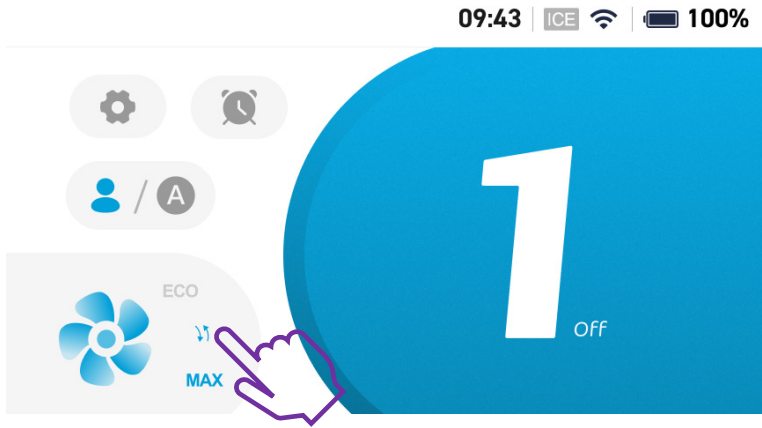

4. Push the machine to the area you want to clean. To prevent any damage to the floor, keep machine moving forward while in operation.

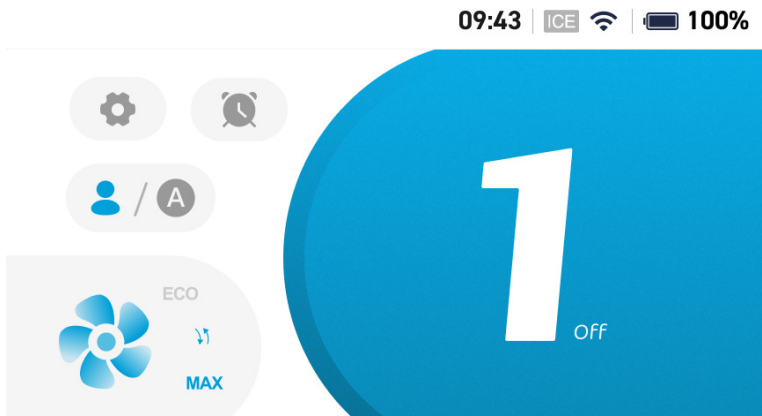

5. Tap the 1-step start icon to end manual cleaning. The brush motor will stop immediately, the vacuum motor will shut off after 15 seconds and the screen display will return to the Manual Mode main interface.



Machine Maintenance

To ensure optimal performance regardless of cleaning mode, daily and weekly maintenance is required.

Daily Maintenance

- 1. Turn off the Main power switch and ensure the machine is turned off.



- 2. Remove the Tank Assy from the machine and carry it to the service area, empty and rinse both the Solution Tank and the Recovery tank.



- 3. Remove the Squeegee Assy from the machine and clean it by flushing it with water, then wiping with clean cloth.



Machine Maintenance

4. Remove the debris hopper from the machine, tap out the debris and rinse by flushing it with water.

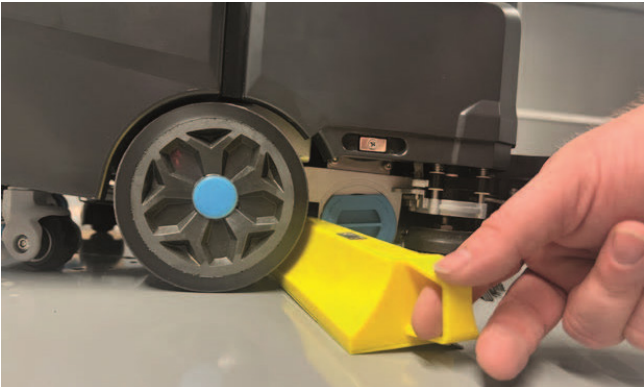

5. Remove microfiber mop by pulling it off the mop holder. Clean and dry before re-installing.



6. Re-install the tank assembly, squeegee, hopper and mop on the machine. Be sure to install them properly.

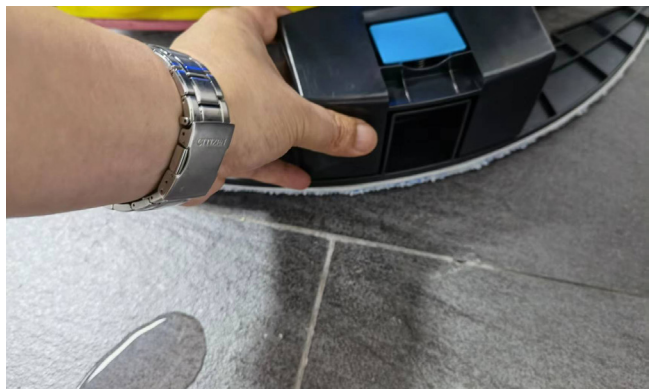

Do not spray the machine exterior directly with water as it may introduce moisture to certain electrical components and cause damage.

Machine Maintenance

7. Wipe cliff sensors with a damp microfiber cloth and ensure there is no residual dirt.

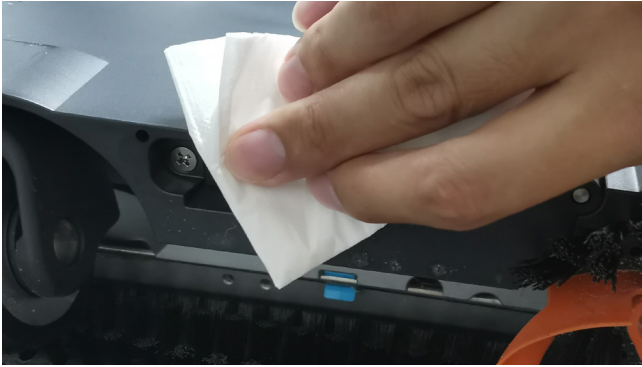

8. Wipe down machine exterior with damp microfiber cloth.



9. Plug battery charger power cord into approved power outlet to charge the battery. The battery power button must be on in order for it to charge. Keep the battery door open for ventilation.

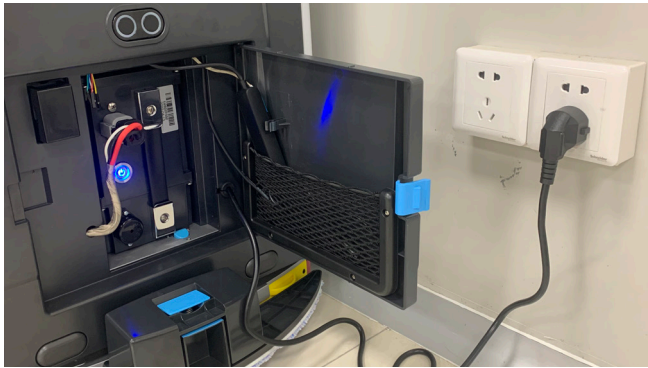

10. Store the machine in an approved area. Folding the handle down will set the parking brake for secure storage.



Machine Maintenance

Weekly Maintenance

1. Turn off the Main power switch and ensure the machine is turned off.



2. Check the main and side brushes for debris. Remove and clean as necessary. Reinstall properly.



3. Remove the water filter on the tank holder and check it for debris build up. Flush with clean water to remove debris and reinstall as needed.

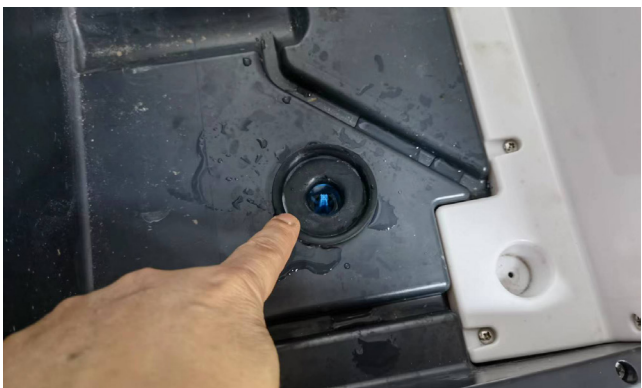

Machine Maintenance

Weekly Maintenance

4. Remove the water distributing tube from the machine, rinse it by flushing it with water, then reinstall.

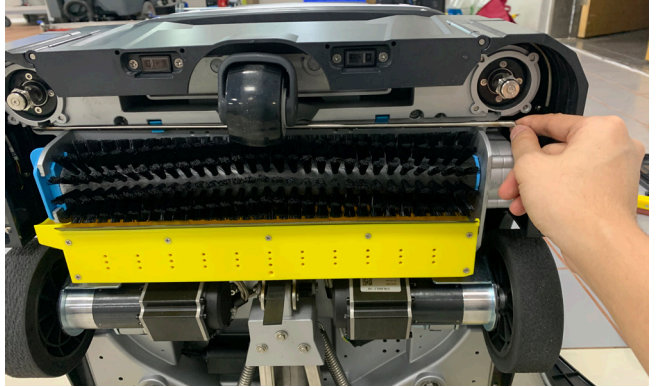

5. Check rubber gaskets on tank holder for debris and damage. Debris may be flushed with clean water and replaced. If a gasket is damaged, it will need to be replaced.



6. Check if the Vacuum hose is clogged, rinse the Vacuum hose by flushing it with water if necessary.

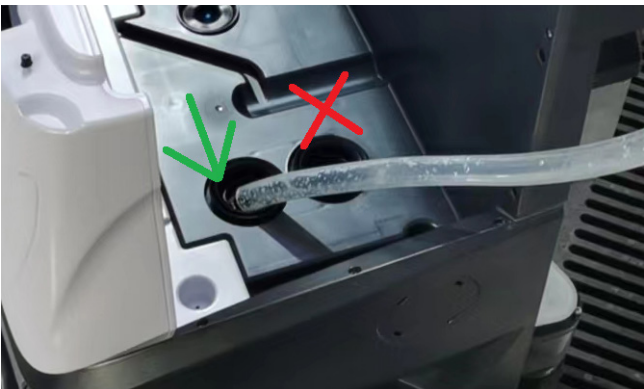

Machine Maintenance

7. Check the recovery tank gasket for debris and damage. Gasket may be cleaned by wiping it off with a damp towel. Damaged gaskets should be replaced with a new one.



8. Wipe-off all cliff sensors with microfiber cloth and ensure there is no residual dirt.



9. Wipe off the machine exterior surface with a damp microfiber cloth.



10. Store the machine in an approved area. Folding the handle down will set the parking brake for secure storage.



Battery & On Board Battery Charger

Cobi 18 has an on board Lithium Ion Battery and battery charger. Do not remove the battery or charger unless authorized to do so.

Battery

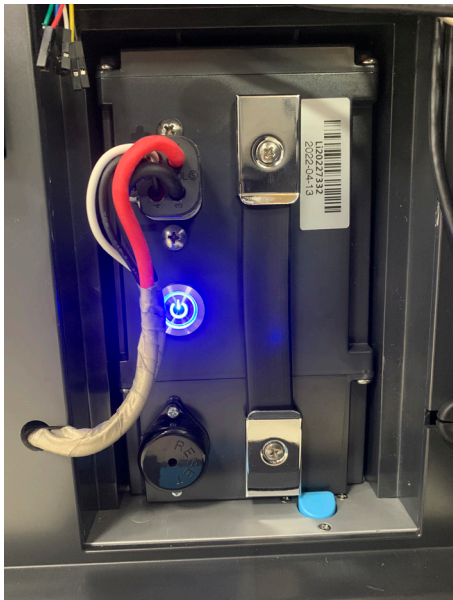

Nominal Voltage	25VDC
Nominal Capacity	25Ah
Allowed Max Charging Current	15A
Charging Temperature	0-45°C (32-113°F) /5~95%RH
Discharge Temperature	20-55°C (68-131°F) /5~95%RH
Storage Temperature	-10-30°C (14-86°F)

1. Only use the specific battery provided with Cobi 18. Do not remove the battery unless authorized.
2. Battery power button must be turned on while machine is charging or while machine is in use.
3. If machine is not being used for a long time, periodic charging may be necessary.
4. Always keep the battery door open for ventilation when charging.

Battery Charger



Input Voltage	100 -240 Vac 50/60 Hz
Output Voltage	24VDC
Charging Current	5A
Temperature & Humidity	0-40°C (32-104°F) /20~55%RH
LED : GREEN ON	Wait for Charging / Fully charged
LED : YELLOW FLASH	Charging in progress
LED : RED FLASH	Charging Error

1. Only use the specific battery charger that Cobi 18 was delivered with. Do not remove the battery charger unless authorized to do so.
2. Always keep the battery door open for ventilation when charging.
3. Connect the AC power cable to approved power supply. A clear window to the right of the battery door will allow visibility to the charging status. Yellow will flash when battery is charging.
4. When the LED turns to Green, the battery is fully charged, unplug the AC power cord and store it on the back of battery compartment door.
5. If the LED light is flashing red, there is a charging error. Please ensure the power cord is plugged into an approved outlet and the battery power button is "on".
6. Please contact ICE Robotics customer service if issue continues to exist.



Troubleshooting

PROBLEM	CAUSE	SOLUTION
Machine does not operate	Low Battery	Recharge the Battery
	Bad Battery	Replace the Battery
	Cable connection fault	Contact ICE Cobotics customer service
	Control unit fault	Contact ICE Cobotics customer service
Brush motor not operational	Brush deck is raised off floor	Lower scrub head
	Faulty brush motor or wiring	Contact ICE Cobotics customer service
Machine does not drive	Faulty traction motor or wiring	Contact ICE Cobotics customer service
	Faulty wheel lift sensor	Contact ICE Cobotics customer service
Vacuum motor not operational	Faulty vacuum motor or wiring	Contact ICE Cobotics customer service
	Control Unit Fault	Contact ICE Cobotics customer service
Little or no solution flow	Water distribution tube clogged	Check and rinse the tube
	Water pump failure	Check and replace the water pump
	Clogged solution tank filter	Clean filter by flushing with water
Poor water pick up	Recovery tank is full	Drain recovery tank
	Clogged float shut-off screen located in recovery tank	Clean screen
	Clogged squeegee assembly	Clean squeegee assembly
	Worn squeegee blades	Replace squeegee assembly
	Incorrect squeegee blade deflection	Adjust squeegee blade height
	Loose vacuum hose connections	Secure hose connections
	Clogged vacuum hose	Remove clogged debris
	Damaged vacuum hose	Replace vacuum hose
	Recovery tank cover not in place	Properly position cover
	Damaged recovery tank gasket	Replace gasket
	Faulty vacuum motor	Contact ICE Cobotics customer service
	Low battery charge	Recharge batteries
Short run time	Low battery charge	Fully recharge battery
	Defective batteries	Replace battery
	Faulty battery charger	Repair or replace battery charger

Fault Code & Solution

Code	Fault Name	Solution
A0002	Emergency button pressed	Release emergency button
A0008	Recovery tank full	Drain recovery tank
A0009	Solution tank empty	Refill solution tank
A0014	Hopper not installed	Install the debris hopper
A0010	Wheel lifted	1. Ensure the machine is operating on a level surface 2. Do not try to lift the machine when the machine is running
A0021	Bumper stuck	1. Check if the bumper is obstructed 2. Inspect machine and environment 3. Reboot the machine 4. If the issue remains, contact customer service
A0022	Cliff Sensor blocked	1. Clean the cliff sensor 2. Reboot the machine 3. If the issue remains, contact customer service
A0139	Low battery	Battery low, recharge battery now
A3022	Handle not in correct position	Push down handle
A3027	Left wheel lifted	1. Ensure the machine is operating on a level surface 2. Do not try to lift the machine when the machine is running
A3028	Right wheel lifted	1. Ensure the machine is operating on a level surface 2. Do not try to lift the machine when the machine is running
A3551	Ground slope too steep	1. Ensure the machine is operating on a level surface 2. Do not try to lift the machine when the machine is running
A3554	Machine close the wall	1. Inspect machine and environment 2. Move machine away from surrounding objects
A3556	Run into narrow corridor	Move machine through narrow corridor
A3557	Machine blocked	1. Inspect machine and environment 2. Move machine away from surrounding objects
A3559	Cannot return to start point	1. Check home location code positioning 2. Check environment near home location code
A3560	Home Location Code not found at end of route	1. Check home location code positioning 2. Check environment near home location code
A3561	Obstacle ahead of Home Location Code	1. Remove the obstacle in front of home location code 2. Check environment near home location code
A3563	Machine has interference	Please remove the obstacle
A3566	Machine detects a large area of glass	1. Please inspect machine and environment 2. Please move machine through the area of glass

Fault Code & Solution

Code	Fault Name	Solution
A0591	Left traction motor overload alert	<ol style="list-style-type: none"> 1. Check if the wheels are stuck or entangled by objects 2. Inspect machine and environment 3. Reboot the machine 4. If issue remains, contact customer service
A0611	Right traction motor overload alert	<ol style="list-style-type: none"> 1. Check if the wheels are stuck or entangled by objects 2. Inspect machine and environment 3. Reboot the machine 4. If the issue remains, contact customer service
A0751	Main brush motor overload alert	<ol style="list-style-type: none"> 1. Check if the brush is stuck or entangled by objects 2. Reboot the machine 3. If the issue remains, contact customer service
A0791	Left tside brush motor overload alert	<ol style="list-style-type: none"> 1. Check if the brush is stuck or entangled by objects 2. Reboot the machine 3. If the issue remains, contact customer service
A0811	Right side brush motor overload alert	<ol style="list-style-type: none"> 1. Check if the brush is stuck or entangled by objects 2. Reboot the machine 3. If the issue remains, contact customer service
A0991	Scrub deck actuator overload alert	<ol style="list-style-type: none"> 1. Check if the scrub deck actuator is stuck or entangled by objects 2. Reboot the machine 3. If the issue remains, contact customer service
A1011	Squeegee actuator overload alert	<ol style="list-style-type: none"> 1. Check if the squeegee actuator is stuck or entangled by objects 2. Reboot the machine 3. If the issue remains, contact customer service
A1131	Vacuum motor overload alert	<ol style="list-style-type: none"> 1. Reboot the machine 2. If the issue remains, contact customer service
A1291	Water pump overload alert	<ol style="list-style-type: none"> 1. Reboot the machine 2. If the issue remains, contact customer service
A0035	Service deactivated	Serial number: - The service you subscribed has expired, please enter the password to reactivate or contact customer service
A0036	Service deactivated	Serial number: - The trial period of the machine has expired, please contact customer service
A0037	Service deactivated	Serial number: - Please contact the customer service center
A0038	Service deactivated	Serial number: - Service not active, contact customer service

Wiring Diagram

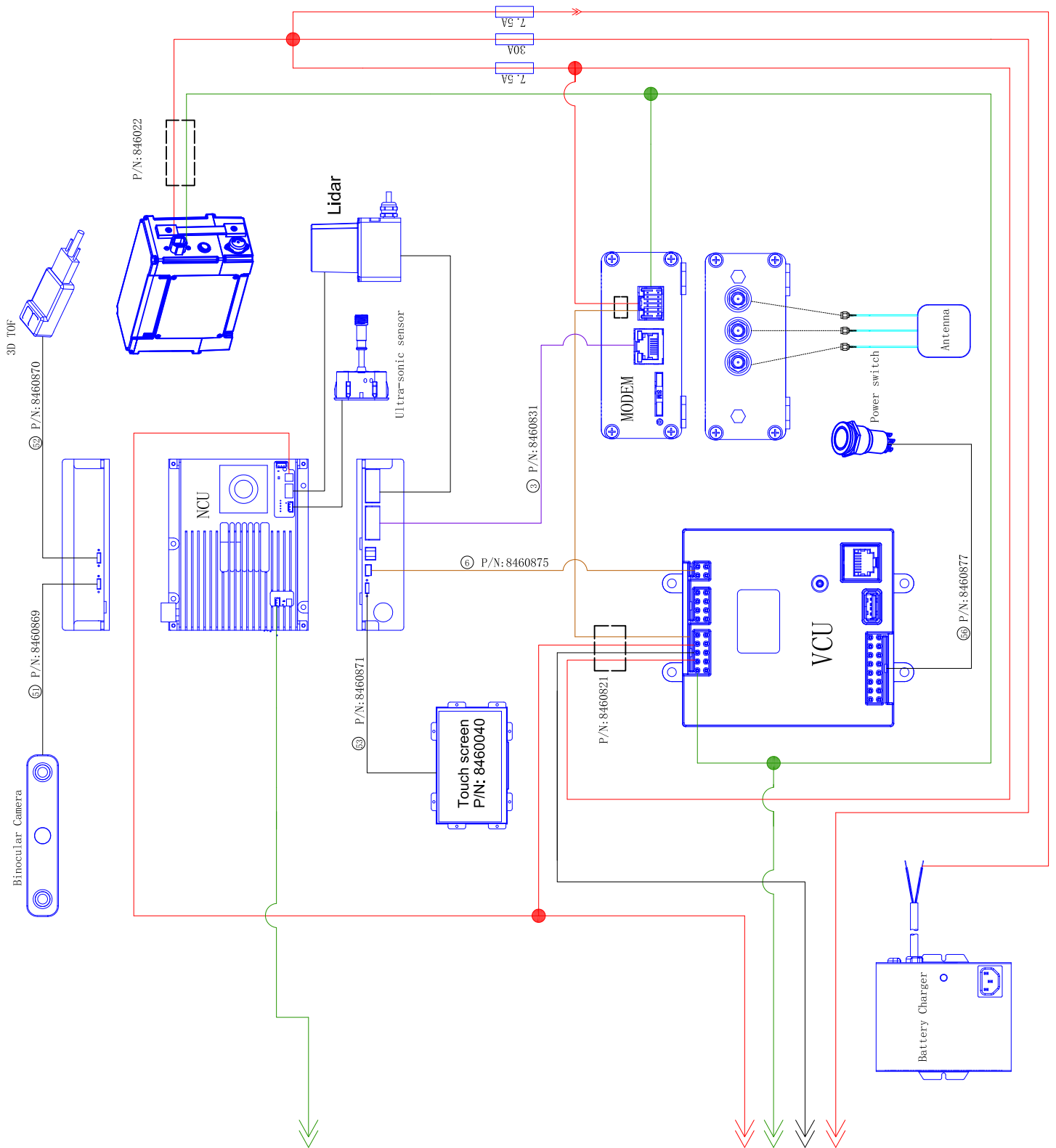

Wiring Diagram

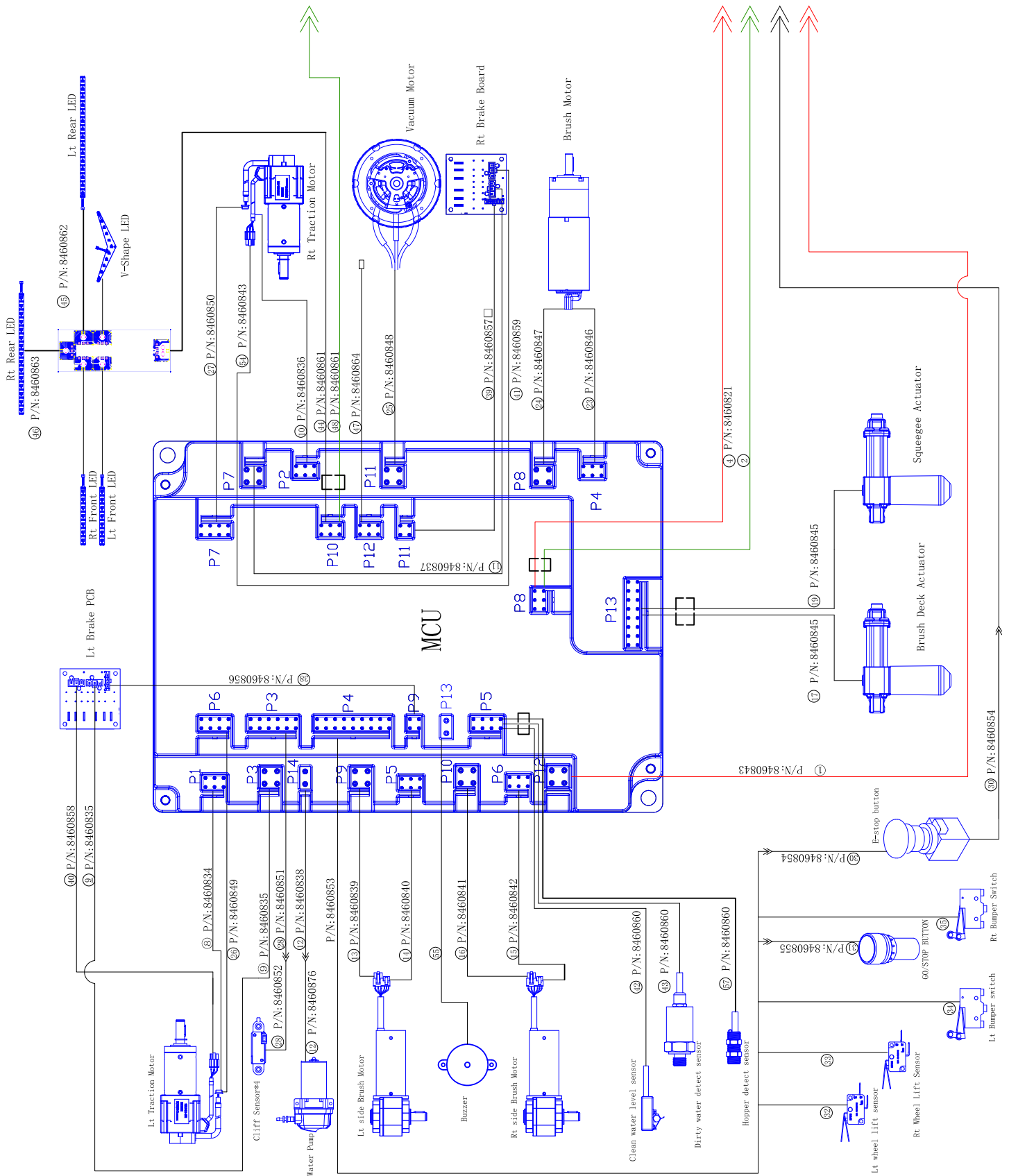

Declaration of Conformity

ICE Cobotics Hong Kong
Rm 3512-3522, No. 1 Hung To Road Kwun Tong, Kowloon, Hong Kong, China

ICE Cobotics China
2F, Building #5, 1151 Lianxi Road Pudong, Shanghai, China

ICE Cobotics US
101 E. Roosevelt Street Zeeland, MI 49464, United States

ICE Cobotics EMEA
Airborne Avenue 55
2133 LV Hoofddorp, The Netherlands

Herewith we declare that the product

Cobot Scrubber

Model number: Cobi 18

Serial number range: 60401 000001 - 60401 999999

is in conformity with the following European Directives and harmonised standards

2006/42/EC, 2014/30/EU,

EN 60335-1:2012+A11:2014+A13:2017+A1:2019+A14:2019+A2:2019+A15:2021

EN 60335-2-72:2012

EN 62233:2008

EN IEC 61000-6-1:2019

EN IEC 61000-6-3:2021

EN 61000-3-2:2019+A1:2021

EN 61000-3-3:2013+A1:2019

07. 01, 2022